



Technical Data

Immersible Coolant Pump - SBKI 3-10/10

Revision no.

Page:
 1

	Receiver	From
Company name		
Respons. Department		
Person in charge		
Phone number		
Fax no		
E-mail address		



Brand: Gol Pumps
Model: SBKI 3-10/10
Material: Stainless Steel

Enclosure Class	IP55
Insulation Class	F
Liquid Temp. Range	-50 °F to +194 °F
Max. ambient temp.	+122 °F
Mechanical Seal	SUUUV

Dimensions:

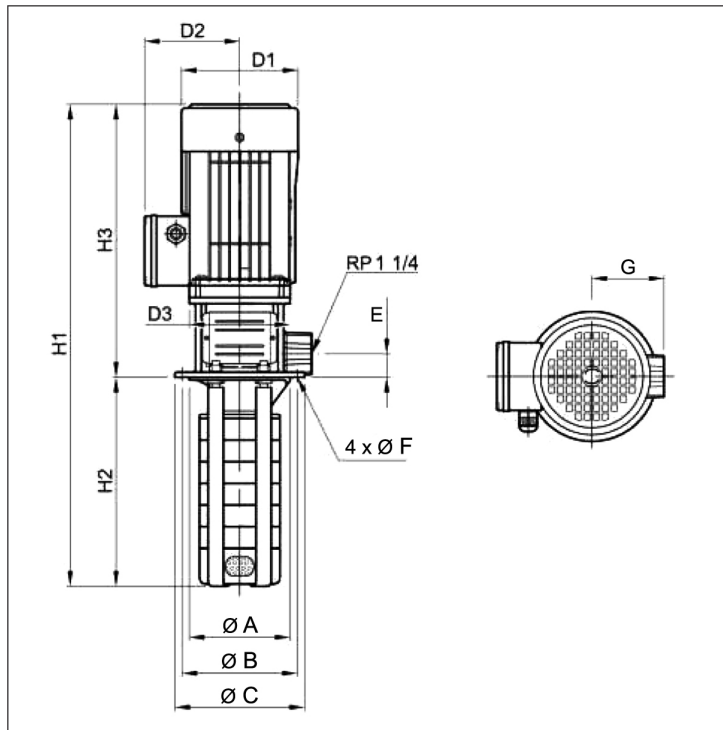

Pump Installation Size (inch)													Weight
Outlet	A	B	C	E	F	G	H1	H2	H3	D1	D2	D3	lb
RP 1 1/4	5.5	6.3	7.1	1.3	0.3	3.9	28	12	16	7	5.6	5.5	58.7

Project	Project ID	Created by	Created on	Last update
---------	------------	------------	------------	-------------



Performance Curves

Immersible Coolant Pump - SBKI 3-10/10

Revision no. _____
 Page: 2

Receiver	From

Company name _____
 Respons. Department _____
 Person in charge _____
 Phone number _____
 Fax no _____
 E-mail address _____

Model	Capacity			Head		Speed	Motor	Voltage	Phase	Amps	Eff.	(NPSH)r
	m ³ /h	l/m	gpm	m	ft	r/min	hp	v			%	ft
SBKI 3-10/10	5.5	90	23.8	95	311.7	3450	2	230	1	9.6	58	14.8

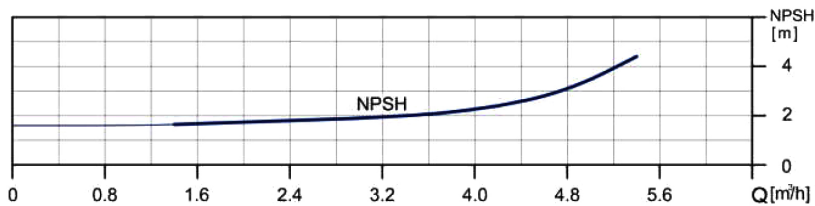
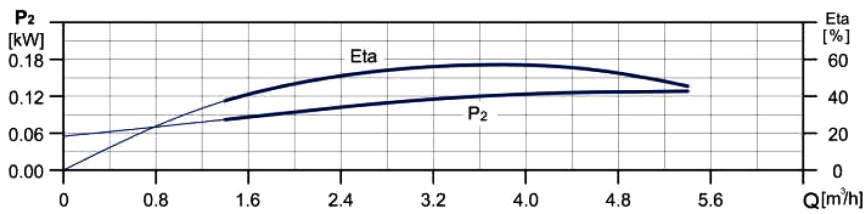
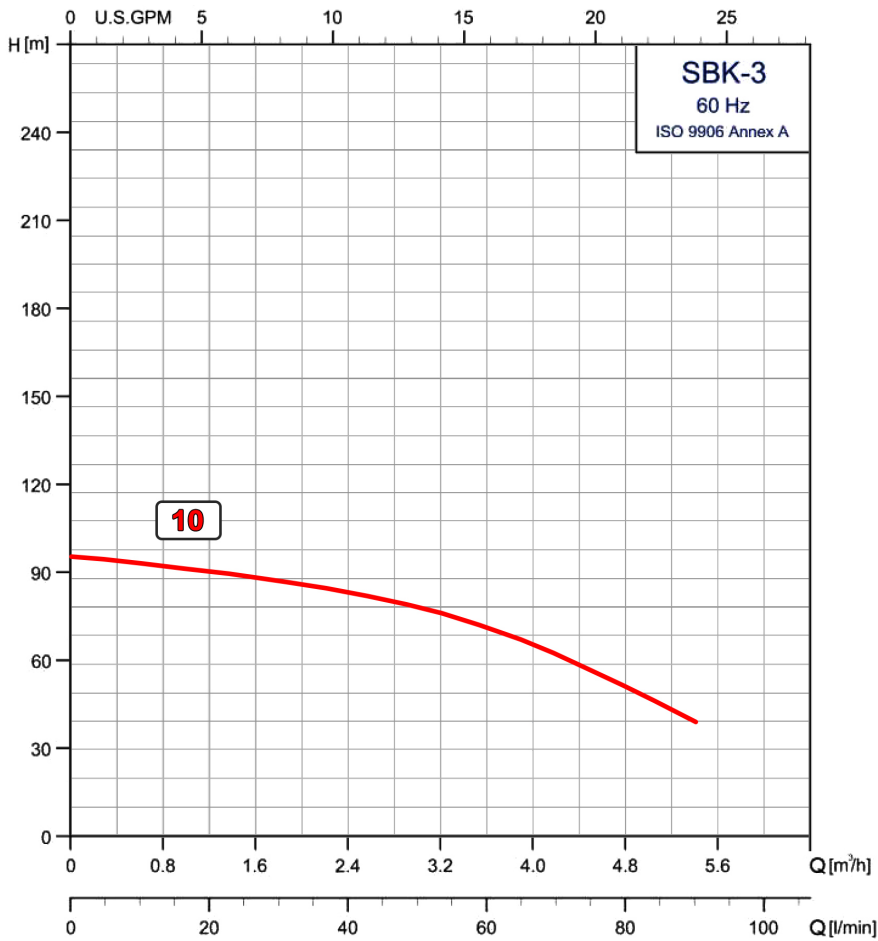

Project	Project ID	Created by	Created on	Last update
---------	------------	------------	------------	-------------



Parts and Materials

Multi-Stage Horizontal Pump - SBKI 3-10/10

Revision no. _____
 Page: 3

	Receiver	From
Company name		
Respons. Department		
Person in charge		
Phone number		
Fax no		
E-mail address		

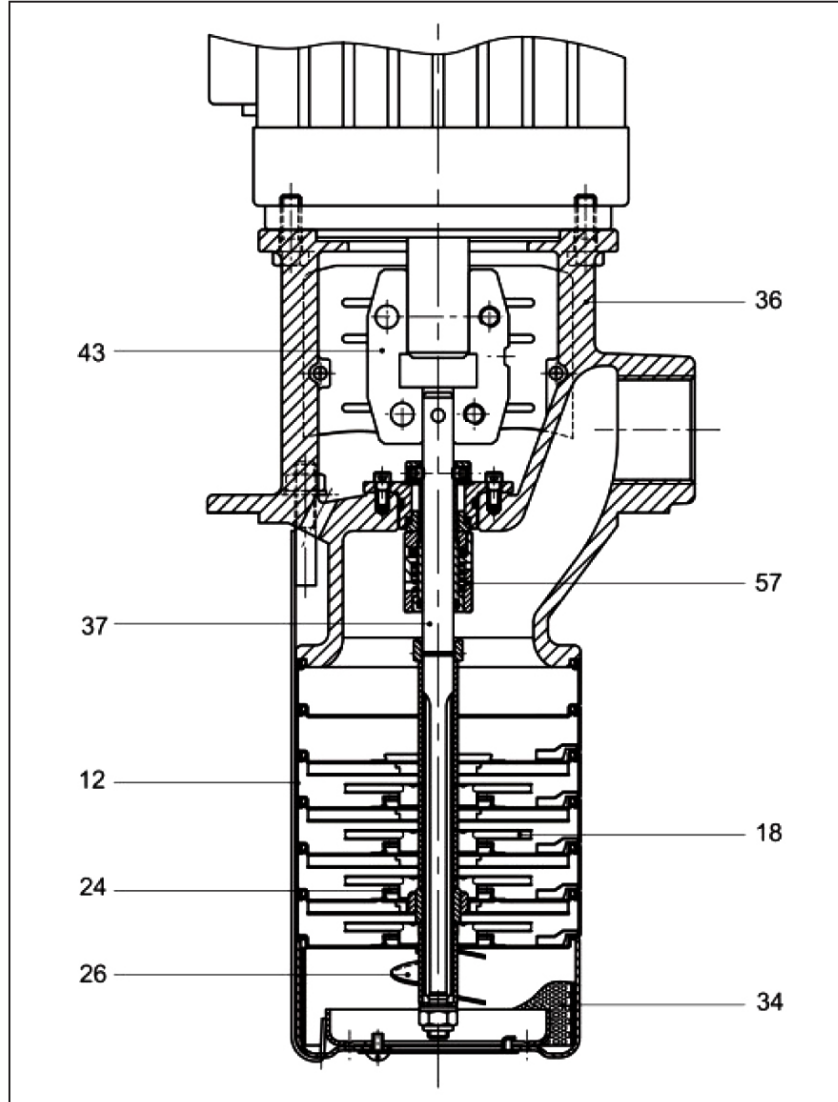

No	Component	Material	AISI/ASTM
12	Chamber Complete	Stainless Steel	AISI 304
18	Impeller	Stainless Steel	AISI 304
24	Neck Ring	PTFE	
26	Priming Screw	Stainless Steel	AISI 304
34	Strainer	Stainless Steel	AISI 304
36	Pump Head	Cast Iron	ASTM 25B
37	Pump Shaft	Stainless Steel	AISI 431
43	Coupling		
57	Shaft Seal	SUUU	

Project	Project ID	Created by	Created on	Last update
---------	------------	------------	------------	-------------



Installation

Immersible Coolant Pump - SBKI 3-10/10

Revision no.

Page:
4

Receiver

From

Company name
Respons. Department
Person in charge
Phone number
Fax no
E-mail address

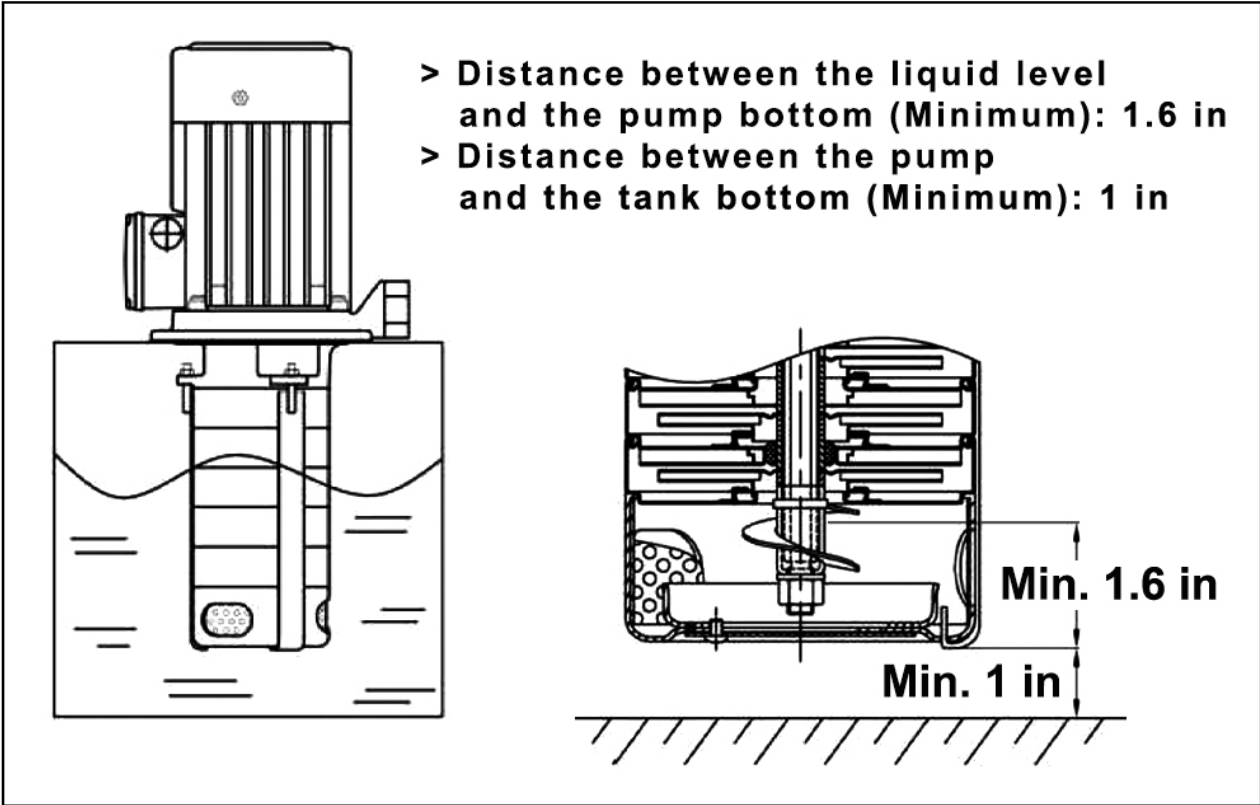

Project

Project ID

Created by

Created on

Last update