

No reproduction of this drawing is allowed without written permission of WEG Motores

EIXO	
PADRÃO	X
OPCIONAL	
ESPECIAL	

Dimensões em polegada  
Dimensions in inches

THIS IS AN UPDATED REVISION, THE PREVIOUS ONE MUST BE DISREGARDED.

A

B

C

D

E

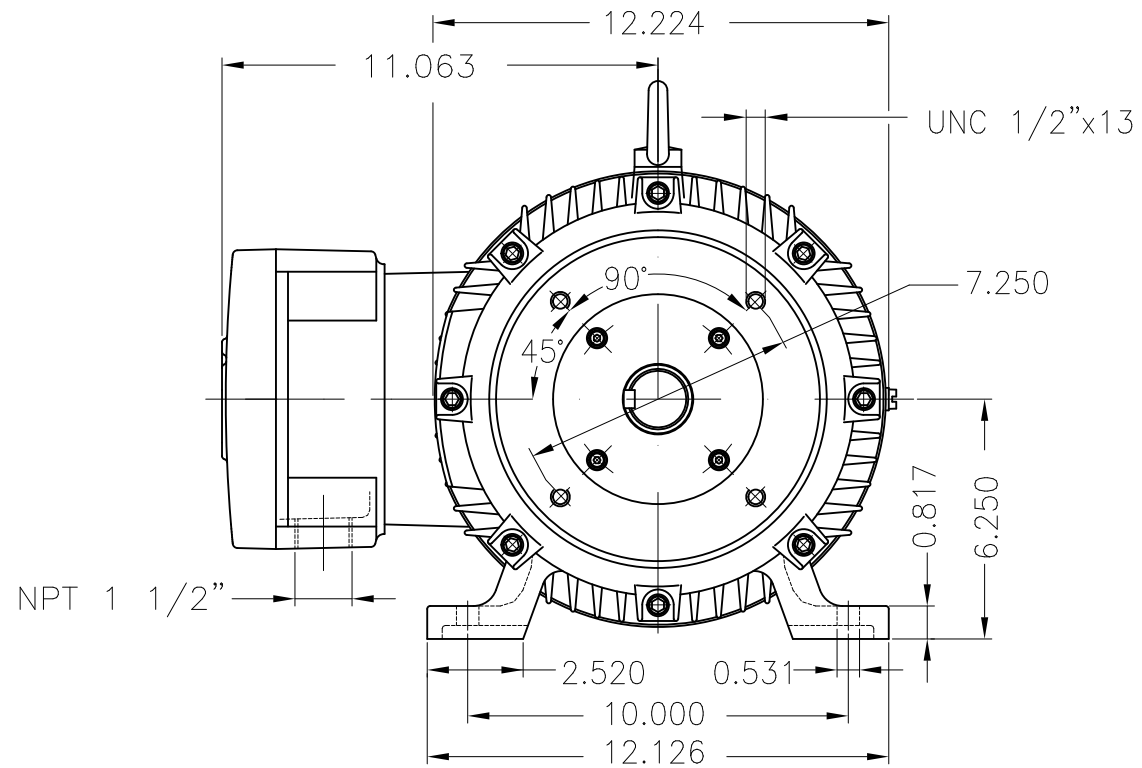

Grounding for leads 5.2–25 mm<sup>2</sup> / 10–4 AWG

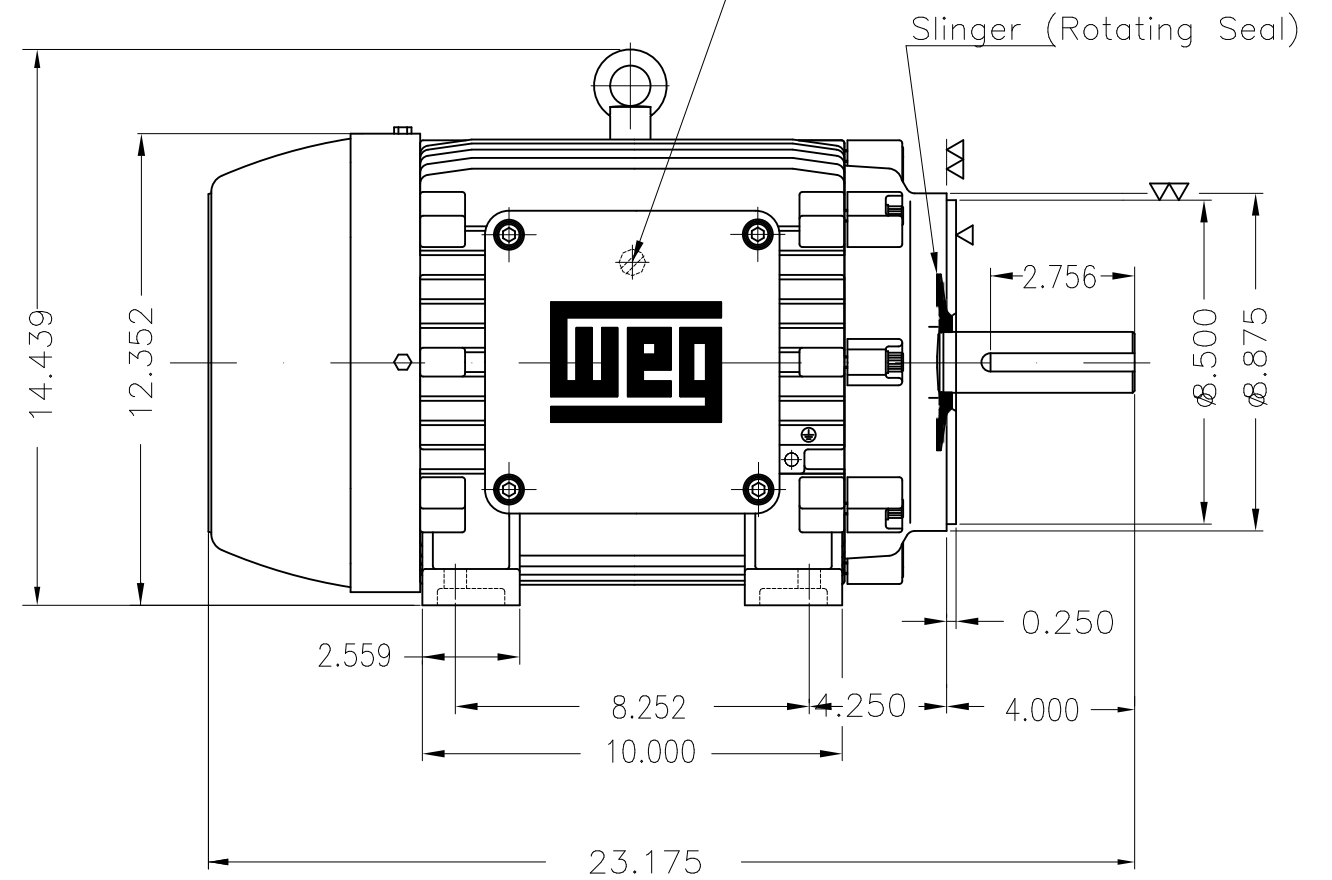

With grease fitting  
Color RAL 5009  
Painting plan 202P  
Mounting B34R(D)

ECM	LOC	SUMMARY OF MODIFICATIONS			EXECUTED	CHECKED	RELEASED	DATE	VER
EXECUTED	USERADMIN		THREE-PHASE EXPLOSION PROOF MOTOR						
CHECKED			FRAME 254TC IP55 TEFC						
RELEASED			WEG code: 14406880						
REL DT	17.02.2022	WMO	Jaragua do Sul	Product Engineering	SHEET	1 / 1			

15 HP 04 Poles 60Hz

A



# DATA SHEET



## Three Phase Induction Motor - Squirrel Cage

Customer :																			
Product line	: W21 Explosion Proof NEMA Premium Efficiency Three-Phase																		
Product code :	14406880																		
Catalog # :	01518XT3E254TC																		
Frame : 254TC Output : 15 HP (11 kW) Poles : 4 Frequency : 60 Hz Rated voltage : 230/460 V Rated current : 36.8/18.4 A L. R. Amperes : 269/134 A LRC : 7.3x(Code J) No load current : 17.2/8.60 A Rated speed : 1770 rpm Slip : 1.67 % Rated torque : 44.5 ft.lb Locked rotor torque : 300 % Breakdown torque : 300 % Insulation class : F Service factor : 1.15 Moment of inertia (J) : 2.31 sq.ft.lb Design : B	Locked rotor time : 46s (cold) 26s (hot) Temperature rise : 80 K Duty cycle : Cont.(S1) Ambient temperature : -20°C to +40°C Altitude : 1000 m.a.s.l. Protection degree : IP55 Cooling method : IC411 - TEFC Mounting : F-1 Rotation <sup>1</sup> : Both (CW and CCW) Noise level <sup>2</sup> : 69.0 dB(A) Starting method : Direct On Line Approx. weight <sup>3</sup> : 330 lb																		
Output	25%    50%    75%    100%																		
Efficiency (%)	89.4    90.2    91.7    92.4																		
Power Factor	0.39    0.65    0.75    0.81																		
Foundation loads																			
Max. traction : 531 lb																			
Max. compression : 861 lb																			
	<table border="0"> <tr> <td></td> <td style="text-align: center;"><u>Drive end</u></td> <td style="text-align: center;"><u>Non drive end</u></td> </tr> <tr> <td>Bearing type :</td> <td>6309 C3</td> <td>6209 C3</td> </tr> <tr> <td>Sealing :</td> <td>Oil Seal</td> <td>Lip Seal</td> </tr> <tr> <td>Lubrication interval :</td> <td>20000 h</td> <td>20000 h</td> </tr> <tr> <td>Lubricant amount :</td> <td>13 g</td> <td>9 g</td> </tr> <tr> <td>Lubricant type :</td> <td colspan="2" style="text-align: center;">Mobil Polyrex EM</td> </tr> </table>		<u>Drive end</u>	<u>Non drive end</u>	Bearing type :	6309 C3	6209 C3	Sealing :	Oil Seal	Lip Seal	Lubrication interval :	20000 h	20000 h	Lubricant amount :	13 g	9 g	Lubricant type :	Mobil Polyrex EM	
	<u>Drive end</u>	<u>Non drive end</u>																	
Bearing type :	6309 C3	6209 C3																	
Sealing :	Oil Seal	Lip Seal																	
Lubrication interval :	20000 h	20000 h																	
Lubricant amount :	13 g	9 g																	
Lubricant type :	Mobil Polyrex EM																		
Notes USABLE @208V 40.7A SF 1.15 SFA 46.8A																			
This revision replaces and cancel the previous one, which must be eliminated. (1) Looking the motor from the shaft end. (2) Measured at 1m and with tolerance of +3dB(A). (3) Approximate weight subject to changes after manufacturing process. (4) At 100% of full load.																			
These are average values based on tests with sinusoidal power supply, subject to the tolerances stipulated in NEMA MG-1.																			
Rev.	Changes Summary	Performed	Checked	Date															
Performed by																			
Checked by			Page	Revision															
Date	17/02/2022		1 / 2																

# DATA SHEET

## Three Phase Induction Motor - Squirrel Cage



Customer : \_\_\_\_\_

### Thermal protection

ID	Application	Type	Quantity	Sensing Temperature
1	Winding	Thermostat - 2 wires	1 x Phase	155 °C

Rev.	Changes Summary	Performed	Checked	Date
Performed by				
Checked by			Page	Revision
Date	17/02/2022		2 / 2	

MADE IN BRAZIL

**W21X NEMA**  
**Premium**

14406880



LISTED

CC029A

*Inverter Duty Motor*  
*Severe Duty*

MODEL 01518XT3E254TC

PH 3	FR 254TC		
HP(kW) 15.0(11.0)		HZ 60	IP55
V 230/460		A 36.8/18.4	
RPM 1770		NEMA NOM EFF 92.4%	
PF 0.81		SFA 42.3/21.2	DES B
INS CL F $\Delta$ T 80 K		SF 1.15	ENCL TEFC
DUTY CONT.		CODE J	ALT 1000 m.a.s.l.
AMB 40°C	USABLE @208V	40.7 A	SF 1.15 SFA 46.8
AMB 55°C SF1.0			
15HP 11kW 50Hz 380V 22.1A 1455RPM SF1.00 EFF 90.2% (IE2)			

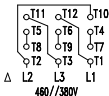
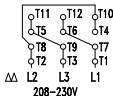

→ 6309-C3 MOBIL POLYREX EM  
→ 6209-C3 13 g 20000 h

333 Lbs



TEMP CODE T3C  
CSA/UL: Class I - Div. 1 - Groups C and D  
CSA: Class II - Div. 1 - Groups F and G  
CSA: Class I - Zone 1 - IIB

EXPLOSION PROOF MOTOR

FOR USE ON VPWM VFD 1000:1VT, 6:1CT, 1.0SF, T3C, AMB 40°C.