

SMART VOX BASE 400

Residue Pump

60 Hz

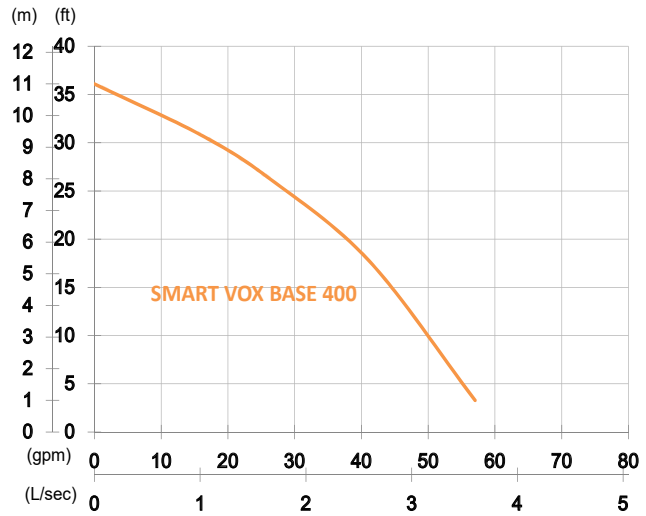

Shaft Speed : 3450 rpm

Outlet : 50mm, 2in

OUTPUT	HEAD	FLOW
0.4 kW	Rated : 8m, 26ft	Rated : 1.6L/s, 26gpm
0.5 HP	Max : 11m, 36ft	Max : 3.6L/s, 58gpm

Solid Passage : 2mm, 0.1in

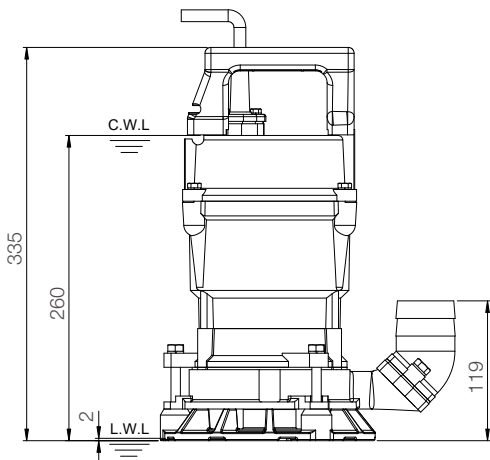
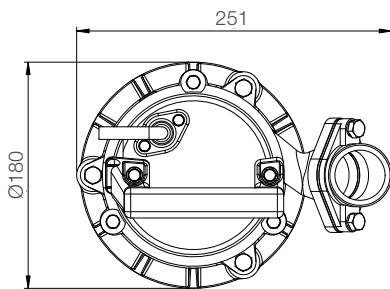

unit : mm

Weight : 11.3kg / 25 lbs

Pump Type	Electric Submersible Pumps	
	1-Phase, 110V or 220V	
Motor	Type	Induction Motor
	Poles	2 Pole
	Insulation	Class F
	Protector	Miniature Thermal Protector
	Starter	Capacitor-Run
Lubricant	Food Grade (ISO VG32)	
Impeller Type	Semi-Vortex	
Shaft Seal	Double Mechanical Seal	
	Silicon Carbide VS Ceramic / Carbon	
Bearings	C3 Shielded ball bearings	
Cable	PVC (CSA Certified) / H07RN-F	
	10m (33ft) or longer upon request.	
Materials	Pump Casing	Gray Iron
	Impeller	Synthetic Polymers
	Motor Frame	Aluminum
	Motor Shaft	Stainless Steel
	Agitator	Stainless Steel
	Strainer	Synthetic Polymers
Max. Liquid Temperature	40°C (104°F)	
Max. Submersion Depth	20m (66ft)	
pH Range	pH 5 - pH 8	