

TANK 237

60 Hz

High Chrome Dewatering Pump

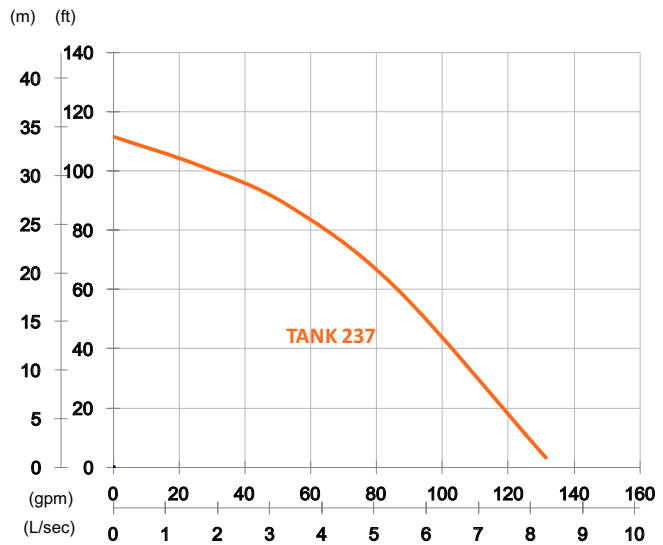

Shaft Speed : 3450 rpm

Outlet : 50mm, 2in

OUTPUT	HEAD	FLOW
3.7 kW	Rated : 27m, 89ft	Rated : 3.3 L/s, 53 gpm
5 HP	Max : 34m, 112ft	Max : 8.3 L/s, 132 gpm

Solid Passage : 10mm, 0.4in

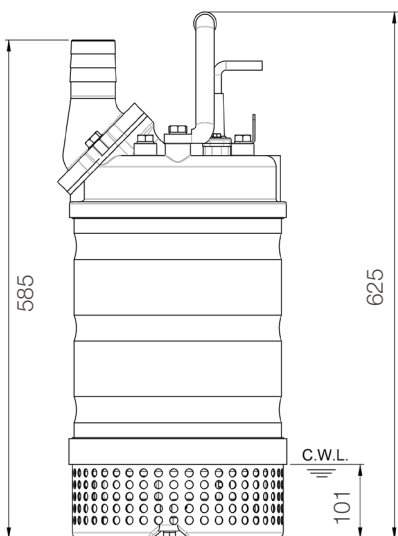
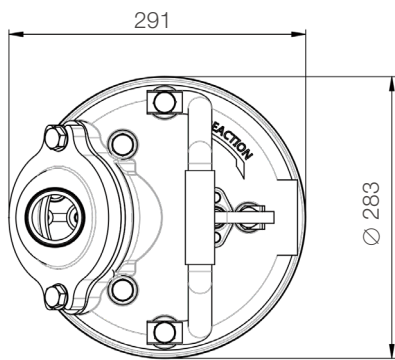

unit : mm

Weight : 61kg / 134 lbs

Pump Type		Electric Submersible Pumps
		3-Phase, 220V
Motor	Type	Induction Motor
	Poles	2 Pole
	Insulation	Class F
	Protector	Circle Thermal Protector
	Starter Method	3-Phase · D.O.L.
Lubricant		Food Grade (ISO VG32)
Impeller Type		Opened
Shaft Seal		Double Mechanical Seal
		Silicon Carbide VS Ceramic / Carbon
Bearings		C3 Shielded ball bearings
Cable		PVC (CSA Certified) / H07BQ-F
		10m (33ft) or longer upon request.
Materials	Pump Casing	Gray Iron
	Impeller	Chromium Iron
	Motor Frame	Stainless Steel
	Motor Shaft	Stainless Steel
	Strainer	Stainless Steel
Max. Liquid Temperature		40°C (104°F)
Max. Submersion Depth		20m (66ft)
pH Range		pH 5 - pH 8