

# DATA SHEET

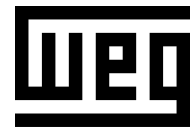

## Three Phase Induction Motor - Squirrel Cage

Customer : \_\_\_\_\_

Product line : NEMA Premium Efficiency Three-Phase  
 Product code : 5160748  
 Catalog # : 03018ET3E286TS-W22

Frame	: 284/6TS	Locked rotor time	: 36s (cold) 20s (hot)
Output	: 30 HP (22 kW)	Temperature rise	: 80 K
Poles	: 4	Duty cycle	: Cont.(S1)
Frequency	: 60 Hz	Ambient temperature	: -20°C to +40°C
Rated voltage	: 230/460 V	Altitude	: 1000 m.a.s.l.
Rated current	: 70.2/35.1 A	Protection degree	: IP55
L. R. Amperes	: 428/214 A	Cooling method	: IC411 - TEFC
LRC	: 6.1x(Code G)	Mounting	: F-1
No load current	: 26.0/13.0 A	Rotation <sup>1</sup>	: Both (CW and CCW)
Rated speed	: 1765 rpm	Noise level <sup>2</sup>	: 63.0 dB(A)
Slip	: 1.94 %	Starting method	: Direct On Line
Rated torque	: 89.3 ft.lb	Approx. weight <sup>3</sup>	: 465 lb
Locked rotor torque	: 240 %		
Breakdown torque	: 240 %		
Insulation class	: F		
Service factor	: 1.25		
Moment of inertia (J)	: 5.85 sq.ft.lb		
Design	: B		

Output	25%	50%	75%	100%	Foundation loads	
Efficiency (%)	92.3	93.0	93.0	93.6	Max. traction	: 897 lb
Power Factor	0.46	0.70	0.80	0.84	Max. compression	: 1362 lb

		<u>Drive end</u>	<u>Non drive end</u>
Bearing type	:	6311 C3	6211 C3
Sealing	:	V'Ring	V'Ring
Lubrication interval	:	20000 h	20000 h
Lubricant amount	:	18 g	11 g
Lubricant type	:	Mobil Polyrex EM	

Notes  
 USABLE @208V 77.6A SF 1.15 SFA 89.3A

This revision replaces and cancel the previous one, which must be eliminated.  
 (1) Looking the motor from the shaft end.  
 (2) Measured at 1m and with tolerance of +3dB(A).  
 (3) Approximate weight subject to changes after manufacturing process.  
 (4) At 100% of full load.

These are average values based on tests with sinusoidal power supply, subject to the tolerances stipulated in NEMA MG-1.

Rev.	Changes Summary	Performed	Checked	Date
Performed by		Page		Revision
Checked by		1 / 1		
Date	23/06/2022			

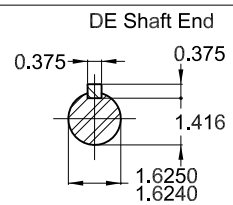
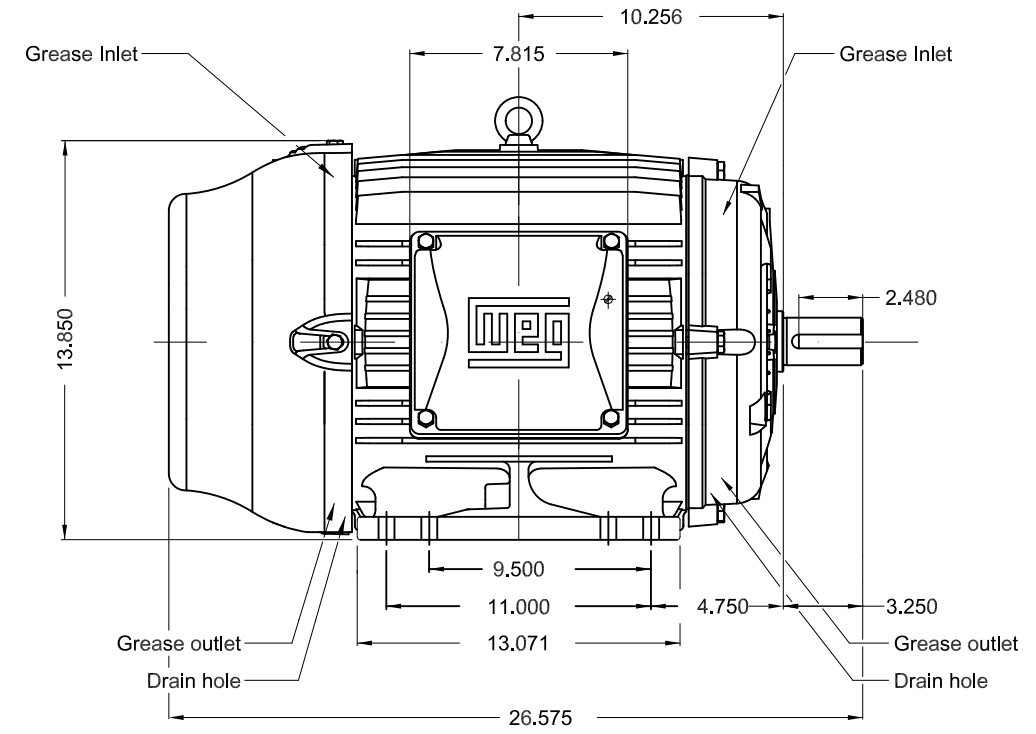
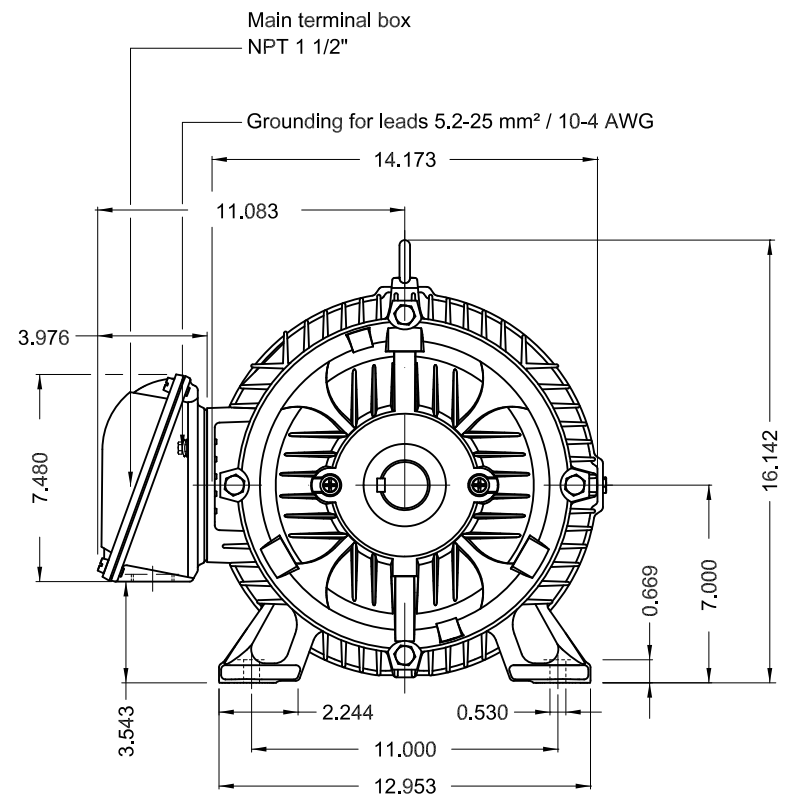

TS shaft end  
 Color RAL 5009  
 Painting plan 203A  
 Mounting B3R(D)

30 HP 04 Poles 60 Hz A

ECM	LOC	SUMMARY OF MODIFICATIONS	EXECUTED	CHECKED	RELEASED	DATE	VER
EXECUTED	HYBRISUSER	THREE PH. MOTOR W22 PREM. EFF.					
CHECKED		FRAME 284/6TS IP55 TEFC					
RELEASED							
REL DT.	WMO	Jaragua do Sul	Product Engineering				

**PREVIEW**  
 WDD



SHEET 1 / 1



FOR SAFE AREA  
Mod.TE1BFOXON  
CC029A



For use on 60Hz  
Class I, Div 2, Gr A, B, C and D - T3  
Class I, Zone 2, IIC - T3  
Class II, Div 2, Gr F and G - T4  
For use on PWM: Gr. A, B, C, D and F,  
VT 1000:1, CT 20:1, 1.00SF - T3A

MODEL 03018ET3E286TS-W22

Inverter Duty Motor  
Severe Duty

PH3 60Hz Fr. 284/6TS 1000m.a.s.l. IP55 TEFC 438lb

V 230/460

A 70.2/35.1

HP 30

kW 22

SF 1.25

SFA 87.8/43.9

RPM 1765

PF 0.84

AMB 40°C

INS cl. F DT80K NEMA NOM EFF 93.6%

DUTY CONT.

DES B Code G

USABLE @208V 77.6A SF 1.15 SFA 89.2

30HP 22kW 50Hz 380V 43.1A 1445RPM SF 1.00 EFF 90.2% (IE1)

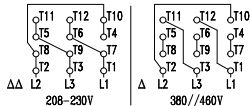

→ 6311-C3 (18g)  
 → 6211-C3 (11g)

MOBIL POLYREX EM (20000h)

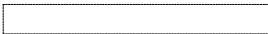

MADE IN MEXICO  
11457167