



GOL PUMPS CO.



**4" & 6" Encapsulated Motors
OPERATING INSTRUCTIONS**

Index

1 Guidelines	01
2 Safety	01
3 Intended use	02
4 Transport and storage	02
5 Number of Starts	02
6 Control boxes (Only apply for single phase 4" motor)	03
7 Connecting the motor cable	07
8 Extending the motor cable	07
9 Assembly of motor and pump	12
10 Electrical connection	14
11 Work on the motor	15
12 Water Temperature and Flow	15
13 Installation Position	16

1 Guidelines

This Encapsulated-resin filled motor is a machine component in accordance with the EN 60034-1 and NEMA MG1-18.388. The motor must not be committed until

- a complete motor is manufactured
- the safety requirements meet the stipulation in the applicable EN 60034-1 and NEMA MG1-18.388 and confirm by the certificate of conformity.

2 Safety

The submersible motor must only be operated under the following safety regulations:

- Consider the limits of implementation of the pump and motor
- Before switching-on the motor, analysis the electrical system and fusing
- Keep the electrical and mechanical danger out of access
- Only operate the motor under the water
- In order to avoid the water hammer effect when starting-up, Vent rising pipe before commissioning
- Install a check valve in the pump or in the rising pipe
- The temperature of water supply should not below -3°C , and the water filling in the motor should not below 0°C .
- The maximum temperature of the water supply is 30°C . temperatures higher than 30°C will only derate motor efficiency and durance.
- When operating generator with the motor, always unloads the generator first. i.e.
 - Starting-up: First the generator, and then the motor
 - Switch-off: First the motor, and then the generator
- After starting up the system check the following points:
 - Rated voltage of the motor running
 - Powering all current of the motor at each phase
 - Water level of the medium to be pumped
- Switching off the motor immediately if the following situation happens:
 - The current exceed the rated current on the motor nameplate
 - Comparing to the rated voltage and the voltage measured on the motor,

3 Intended use

This Canned (Encapsulated) type motor is designed for submersible operation as a driver of variable torque loads such as a water pump. i.e.

- Drinkable water supply
- Wells for domestic uses, waterworks and agriculture usage
- Dewatering, pressure boosting, irrigation systems
- Processed water supply
- Ground water heating systems
- The maximum submergence depth for the Canned (Encapsulated) type motor is 200 meters.
- The material of SS316 stainless steels is available for operation in aggressive environments. The responsibility for correct material choosing lies with the customers.

4 Transport and storage

- Only take the motor out of the original packaging when ready for assembly.
- Do not store the motor at temperatures over 62°C at any circumstance, which may result in liquid leakage and motor failure.
- Do not store the motor at temperatures in environment where is below -12°C and please make sure the water filling is frost-free.

5 Number of Starts

Rapid cycling of motor start/shut down can reduce motor life, resulted from motor spline damage, bearing damage, and motor overheating. The average number of starts per day over a period of months or years also affects the durance of a submersible pumping system. The pump/ motor should be selected to keep the starts per day as low as possible to be practical for the longest life.

The maximum number of starts per 24-hour is shown in below list.

Motor Rating Maximum Starts Per 24 hr Period

Motor Rating		Maximum Starts Per 24 hr Period	
HP	kW	Single Phase	Three-Phase
0.75HP and below	0.55kW and below	300	300
1HP- 5.5HP	0.75kW- 4kW	100	300
7.5HP- 30HP	5.5kW-22kW	50	100
40HP and above	30kW and above	-	100

Four-inch motors should run a minimum of one minute to avoid heat buildup from starting current, and Six-inch motors should have a minimum of 15 minutes.

6 Control boxes (Only apply for single phase 4" motor)

Single-phase three-wire 4" submersible motors are required to be used with control boxes. Operating motors with incorrect control boxes or without using control boxes can result in motor failure, and it voids warranty.

- A control box contains a starting relay, starting capacitor, overload protector, and in a certain size of control box, a running capacitor is also fitted.
- The motor and the control box are two pieces of one assembly. The customer must check if the control box and motor's HP and voltage match or not. The motor is designed to operate with a control box from the same manufacturer, so we can only promise warranty coverage under that circumstance.

6-1 50 HZ RUN CAPACITOR

EU standard

MODEL	TYPE	HZ	POWER	VOLTAGE	REMARK	START CAPACITOR MFD	RUN CAPACITOR UF	RELAY
SBC00R	RUN CAPACITOR (SMALL BOX)	50	0.5HP	220~240V	RUN CAPACITOR * 1 OVERLOAD PROTECTOR*1	-	16UF 450V	-
SBC01R			0.75HP			-	20UF 450V	
SBC02R			1.0HP			-	25UF 450V	
SBC03R			1.5HP			-	35UF 450V	

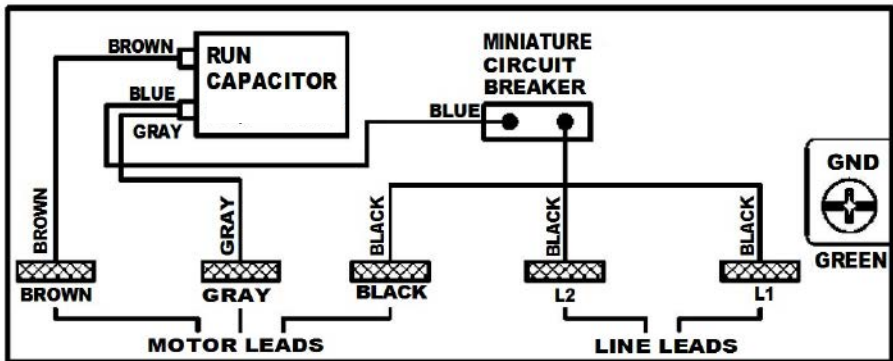

6-2 60 HZ START CAPACITOR

US standard

MODEL	TYPE	HZ	POWER	VOLTAGE	REMARK	START CAPACITOR MFD	RUN CAPACITOR UF	RELAY		
SBC60SA	START CAPACITOR (SMALL BOX)	60	0.5HP	110~115V	START CAPACITOR * 1 + RELAY * 1	250-300MFD 250V	-	P.U:140~153 VAC D.O: 20~ 45 VAC FLA :16A 277V RES:35A 277V		
SBC50SA	START CAPACITOR (SMALL BOX)		0.5HP						220~230V	START CAPACITOR * 1 + RELAY * 1
SBC51SA			0.75HP	86-103MFD 250V	-					
SBC52SA			1.0HP			105-126MFD 250V	-			

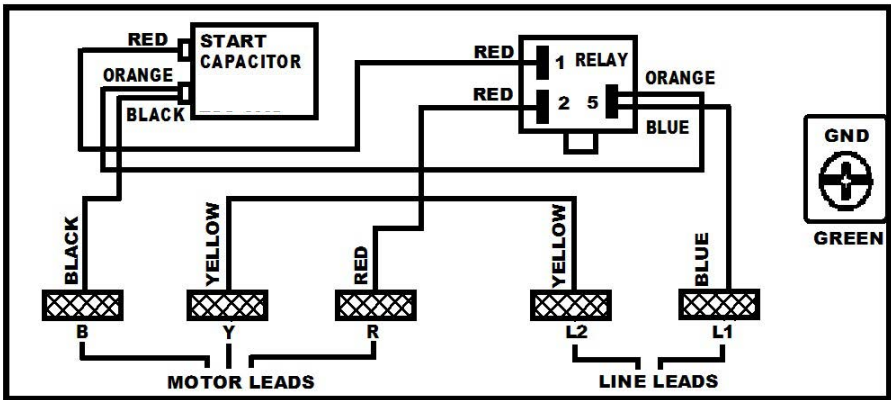

6-3 50 HZ DOUBLE CAPACITOR

EU standard

MODEL	TYPE	HZ	POWER	VOLTAGE	REMARK	START CAPACITOR MFD	RUN CAPACITOR UJF	RELAY
BBC03D	DOUBLE CAPACITOR (BIG BOX)	50	1.5HP	220~240V	START CAPACITOR * 1 RUN CAPACITOR * 1 RELAY * 1 OVERLOAD PROTECTOR (1.5 HP * 1` 2-5 HP * 2)	105-126MFD 250V	10UF 400V	P.U:180~195 VAC D.O: 40~105 VAC FLA:16A 277V RES:35A 277V
BBC04D			2.0HP			189-227MFD 250V	20UF 400V	
BBC05D			3.0HP			270-324MFD 250V	35UF 400V	
BBC07D			5.0HP			378-454MFD 250V	75UF 400V	

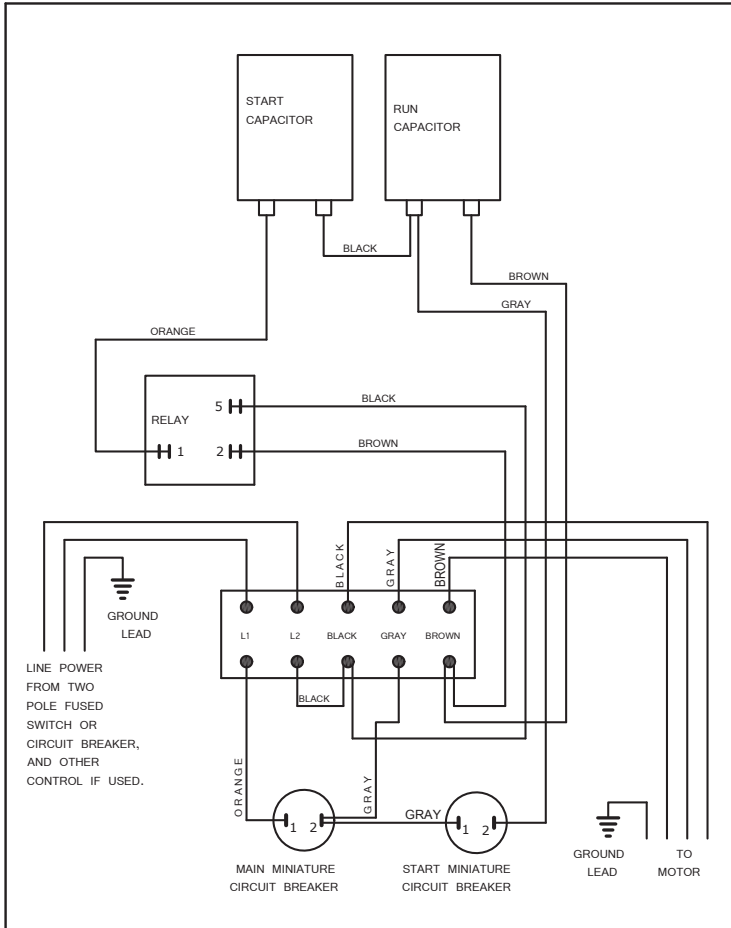

6-4 60 HZ DOUBLE CAPACITOR

US standard

MODEL	TYPE	HZ	POWER	VOLTAGE	REMARK	START CAPACITOR MFD	RUN CAPACITOR UF	RELAY
BBC53DA	DOUBLE CAPACITOR (BIG BOX)	60	1.5HP	220-230V	START CAPACITOR * 1 RUN CAPACITOR * 1 RELAY * 1 OVERLOAD PROTECTOR (1.5 HP * 1 · 2 · 5 HP * 2)	105-126MFD 250V	16UF 400V	P.U:195-224 VAC D.O: 60-121 VAC FLA:16A 277V RES:35A 277V
BBC54DA			2.0HP			105-126MFD 250V	20UF 400V	
BBC55DA			3.0HP			208-250MFD 250V	45UF 400V	
BBC56DA			5.0HP			270-324MFD 250V	80UF 400V	

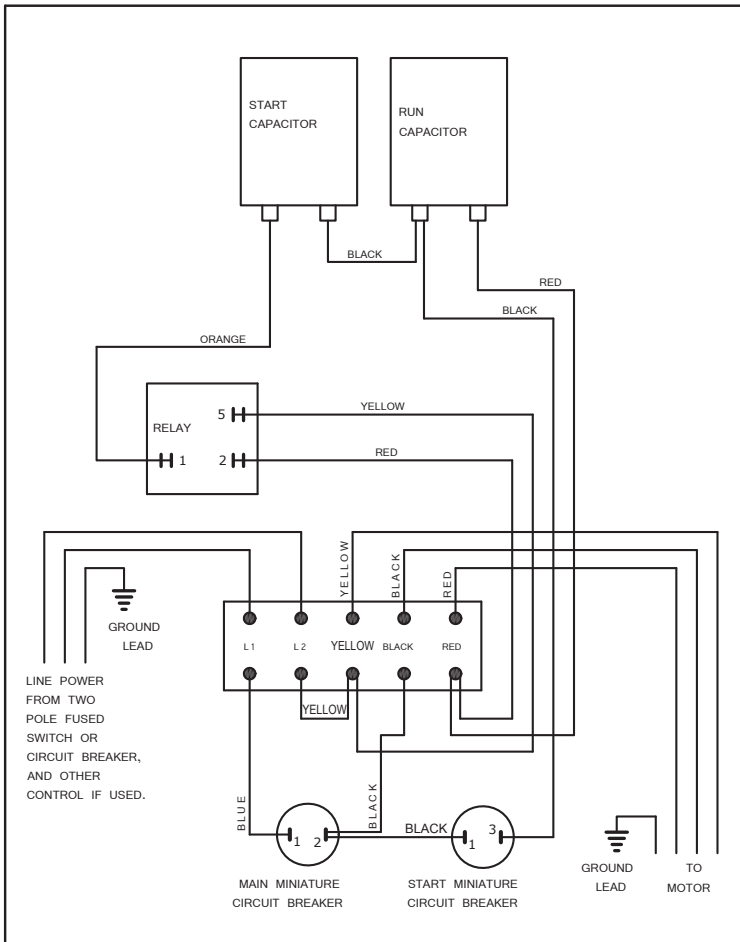

7 Connecting the motor cable

- Before connecting the cable, clear (if any) dirt and moisture from plug and socket.
- Apply some silicone grease or Vaseline to the rubber part of the plug (but make sure no grease reaches the electrical contacts)
- Remove the cable screw from the motor head
- Lubricate the rubber part of the cable plug with silicone oil. Insert the cable plug and push hard to the bottom till a hard stop. Use a slotted screwdriver to tighten up the screw.
- Route the motor leads along the pump, and use a cable guard to protect the leads from damaging.

8 Extending the motor cable

The cable provided can be extended if needed, the customer can complete the extension by one of the following means and follow the safety instruction:

- In order to protect joints against moisture seepage, the customer must use joints with finished cable fittings or shrink hose, sealing compound to prevent it from happening.
- Extension cable must be approved for its use in the medium and the prevailing temperature. (Strictly follow manufacturer's instruction.) The customer are responsible for the correct selection and dimensioning of the drop cable.

8.1 4" Encapsulated-resin filled motor 50 HZ

Single Phase 2 Wire

220-240V50HZ			Metric Cable Size · Square Millimeters · Maximum Length in Meters										
MOTOR	HP	KW	1.5	2.5	4	6	10	16	25	35	50	70	95
4CF2005M	0.5	0.37	118	206	325	492	807	1271	1921	2601	3507	4611	5823
4CF2015M	0.75	0.55	78	136	224	341	566	878	1327	1786	2391	3133	3924
4CF3025M	1	0.75	58	107	175	263	430	674	1026	1397	1886	2492	3157
4CF3035M	1.5	1.1	38	67	115	183	299	472	723	984	1340	1794	2296

Single Phase 3 Wire

220-240V50HZ			Run Capacitor		Metric Cable Size · Square Millimeters · Maximum Length in Meters										
MOTOR	HP	KW	1.5	2.5	4	6	10	16	25	35	50	70	95		
4CF2005R	0.5	0.37	118	206	325	492	807	1271	1921	2601	3507	4611	5823		
4CF2015R	0.75	0.55	78	136	224	341	566	878	1327	1786	2391	3133	3924		
4CF3025R	1.0	0.75	58	107	175	263	430	674	1026	1397	1886	2492	3157		
4CF3035R	1.5	1.1	38	67	115	183	299	472	723	984	1340	1794	2296		

220-240V50HZ			Run & Start Capacitor		Metric Cable Size · Square Millimeters · Maximum Length in Meters										
MOTOR	HP	KW	1.5	2.5	4	6	10	16	25	35	50	70	95		
4CF3035D	1.5	1.1	38	67	116	184	300	475	727	989	1348	1804	2308		
4CF3045D	2.0	1.5	29	58	97	145	243	388	602	826	1147	1546	2013		
4CF4055D	3.0	2.2	18	37	56	94	161	255	388	530	730	976	1251		
4CF6075D	5.0	3.7	-	-	37	56	104	161	246	351	493	674	883		

Three Phase

220-240V50HZ			Metric Cable Size · Square Millimeters · Maximum Length in Meters																
MOTOR	HP	KW	1.5	2.5	4	6	10	16	25	35	50	70	95	120	150	185	240	300	400
4CF2205	0.5	0.37	297	505	812	1219	1992	3132	4767	6482	8811	-	-	-	-	-	-	-	-
4CF2215	0.8	0.55	197	346	544	821	1355	2126	3244	4412	5995	7973	-	-	-	-	-	-	-
4CF3225	1.0	0.75	158	267	426	644	1061	1666	2528	3441	4670	6197	7903	9430	-	-	-	-	-
4CF3235	1.5	1.1	108	187	296	444	741	1156	1769	2402	3272	4350	5556	6624	7701	8868	-	-	-
4CF3245	2.0	1.5	79	139	228	337	566	894	1370	1867	2552	3407	4380	5254	6138	7102	8413	9605	-
4CF4255	3.0	2.2	49	89	148	227	376	594	910	1257	1722	2306	2970	3573	4187	4860	5781	6633	7712
4CF6265	4.0	3.0	39	69	109	168	277	436	664	912	1260	1686	2162	2609	3055	3541	4206	4811	5585
4CF6275	5.5	4.0	28	48	77	115	192	308	471	644	885	1193	1530	1838	2156	2493	2955	3388	3917
4CF6285	7.5	5.5	-	29	58	88	147	235	373	510	697	943	1218	1464	1719	2004	2387	2741	3193

380-415V50HZ			Metric Cable Size · Square Millimeters · Maximum Length in Meters																
MOTOR	HP	KW	1.5	2.5	4	6	10	16	25	35	50	70	95	120	150	185	240	300	400
4CF2105	0.5	0.37	923	1539	2444	3646	5990	9398	-	-	-	-	-	-	-	-	-	-	-
4CF2115	0.8	0.55	624	1040	1654	2476	4061	6379	9698	-	-	-	-	-	-	-	-	-	-
4CF3125	1.0	0.75	486	814	1291	1937	3180	4988	7572	-	-	-	-	-	-	-	-	-	-
4CF3135	1.5	1.1	337	565	902	1348	2221	3490	5305	7219	9807	-	-	-	-	-	-	-	-
4CF3145	2.0	1.5	257	426	693	1030	1704	2674	4081	5577	7618	-	-	-	-	-	-	-	-
4CF4155	3.0	2.2	168	287	456	694	1140	1794	2746	3758	5146	6892	8875	-	-	-	-	-	-
4CF6165	4.0	3.0	119	208	337	505	833	1319	2013	2748	3760	5029	6478	7778	9117	-	-	-	-
4CF6175	5.5	4.0	89	149	248	367	606	964	1471	2008	2754	3679	4723	5678	6642	7697	9129	-	-
4CF6185	7.5	5.5	69	109	188	277	466	734	1131	1548	2123	2848	3672	4426	5200	6044	7195	8267	9627

8.2 4" Encapsulated-resin filled motor 60 HZ

Single Phase 2 Wire

110-115V60HZ			AWG COPPER WIRE SIZE(Maximum Length in Feet)												
MOTOR	HP	KW	14	12	10	8	6	4	3	2	1	0	00	000	0000
4CF2606M	0.5	0.37	90	150	240	370	600	920	1150	1410	1720	2090	2540	3030	3640

220-230V60HZ			AWG COPPER WIRE SIZE(Maximum Length in Feet)												
MOTOR	HP	KW	14	12	10	8	6	4	3	2	1	0	00	000	0000
4CF2506M	0.5	0.37	390	630	990	1570	2450	3790	4700	5740	7010	8520	-	-	-
4CF2516M	0.75	0.55	290	460	730	1160	1810	2800	3470	4240	5170	6280	7640	-	-
4CF3526M	1.0	0.75	240	380	610	960	1490	2310	2870	3500	4280	5200	6330	-	-
4CF3536M	1.5	1.1	180	300	460	740	1160	1816	2250	2760	3390	4150	5080	-	-

Single Phase 3 Wire

110-115V60HZ			AWG COPPER WIRE SIZE(Maximum Length in Feet)												
MOTOR	HP	KW	14	12	10	8	6	4	3	2	1	0	00	000	0000
4CF2606S	0.5	0.37	90	140	230	360	570	890	1100	1350	1650	2000	2440	2920	3500

220-230V60HZ		Start Capacitor	AWG COPPER WIRE SIZE(Maximum Length in Feet)												
MOTOR	HP	KW	14	12	10	8	6	4	3	2	1	0	00	000	0000
4CF2506S	0.5	0.37	380	630	980	1560	2430	3760	4660	5690	6940	8450	-	-	-
4CF2516S	0.75	0.55	290	460	740	1170	1820	2820	3490	4270	5200	6320	7690	-	-
4CF3526S	1.0	0.75	240	390	610	970	1500	2330	2900	3530	4320	5250	6380	-	-

220-230V60HZ		Run & Start Capacitor	AWG COPPER WIRE SIZE(Maximum Length in Feet)												
MOTOR	HP	KW	14	12	10	8	6	4	3	2	1	0	00	000	0000
4CF3536D	1.5	1.1	180	300	460	740	1160	1820	2250	2770	3400	4160	5100	-	-
4CF3546D	2.0	1.5	140	230	370	580	920	1450	1810	2240	2780	3430	4250	-	-
4CF4556D	3.0	2.2	110	180	280	450	720	1140	1430	1780	2230	2780	3470	-	-
4CF6566D	5.0	3.7	-	-	170	270	440	690	870	1080	1360	1700	2120	2620	-

Three Phase

220-230V60HZ			AWG COPPER WIRE SIZE(Maximum Length in Feet)										MCM COPPER WIRE SIZE(Maximum Length in Feet)							
MOTOR	HP	KW	14	12	10	8	6	4	3	2	1	0	00	000	0000	250	300	350	400	500
4CF2906	0.5	0.37	900	1450	2290	3600	5610	8680	-	-	-	-	-	-	-	-	-	-	-	-
4CF2916	0.75	0.55	650	1050	1660	2520	4090	6330	7870	9630	-	-	-	-	-	-	-	-	-	-
4CF3926	1.0	0.75	540	870	1380	2180	3400	5270	6550	8010	-	-	-	-	-	-	-	-	-	-
4CF3936	1.5	1.1	400	640	1020	1610	2520	3920	4870	5960	7290	8880	-	-	-	-	-	-	-	-
4CF3946	2.0	1.5	310	490	780	1240	1950	3040	3870	4640	5700	6980	8550	-	-	-	-	-	-	-
4CF4956	3.0	2.2	230	370	600	960	1490	2330	2890	3550	4350	5310	6500	7790	9400	-	-	-	-	-
4CF6966	4.0	3.0	170	290	460	740	1160	1810	2250	2760	3390	4140	5070	6090	7350	-	-	-	-	-
4CF6976	5.0	3.7	130	220	360	570	890	1390	1740	2140	2620	3210	3930	4740	5730	6490	7380	8260	9010	-
4CF6996	7.5	5.5	-	150	250	410	630	1000	1240	1530	1880	2290	2810	3370	4080	4620	5240	5850	6370	7370

380-400V60HZ			AWG COPPER WIRE SIZE(Maximum Length in Feet)										MCM COPPER WIRE SIZE(Maximum Length in Feet)							
MOTOR	HP	KW	14	12	10	8	6	4	3	2	1	0	00	000	0000	250	300	350	400	500
4CF2806	0.5	0.37	2630	4200	6600	-	-	-	-	-	-	-	-	-	-	-	-	-	-	-
4CF2816	0.75	0.55	1930	3080	4840	7600	-	-	-	-	-	-	-	-	-	-	-	-	-	-
4CF3826	1.0	0.75	1590	2530	3980	6270	9800	-	-	-	-	-	-	-	-	-	-	-	-	-
4CF3836	1.5	1.1	1190	1910	3010	4760	7420	-	-	-	-	-	-	-	-	-	-	-	-	-
4CF3846	2.0	1.5	850	1350	2130	3370	5280	8190	-	-	-	-	-	-	-	-	-	-	-	-
4CF4856	3.0	2.2	660	1070	1680	2640	4130	6390	7890	9670	-	-	-	-	-	-	-	-	-	-
4CF6866	4.0	3.0	500	810	1270	2000	3130	4860	6000	7360	-	-	-	-	-	-	-	-	-	-
4CF6876	5.0	3.7	380	620	980	1540	2410	3760	4640	5700	7020	8580	-	-	-	-	-	-	-	-
4CF6896	7.5	5.5	260	430	670	1060	1670	2580	3190	3920	4830	5890	7140	8610	-	-	-	-	-	-

460V60HZ			AWG COPPER WIRE SIZE(Maximum Length in Feet)										MCM COPPER WIRE SIZE(Maximum Length in Feet)							
MOTOR	HP	KW	14	12	10	8	6	4	3	2	1	0	00	000	0000	250	300	350	400	500
4CF2306	0.5	0.37	3710	5920	9310	-	-	-	-	-	-	-	-	-	-	-	-	-	-	-
4CF2316	0.75	0.55	2680	4270	6720	-	-	-	-	-	-	-	-	-	-	-	-	-	-	-
4CF3326	1.0	0.75	2220	3550	5580	8780	-	-	-	-	-	-	-	-	-	-	-	-	-	-
4CF3336	1.5	1.1	1640	2610	4120	6500	-	-	-	-	-	-	-	-	-	-	-	-	-	-
4CF3346	2.0	1.5	1260	2010	3190	5020	7850	-	-	-	-	-	-	-	-	-	-	-	-	-
4CF4356	3.0	2.2	960	1540	2420	3820	5970	-	-	-	-	-	-	-	-	-	-	-	-	-
4CF6366	4.0	3.0	740	1190	1880	2970	4650	-	-	-	-	-	-	-	-	-	-	-	-	-
4CF6376	5.0	3.7	560	910	1430	2260	3540	5500	-	-	-	-	-	-	-	-	-	-	-	-
4CF6396	7.5	5.5	400	660	1040	1640	2570	3990	4970	6100	7480	-	-	-	-	-	-	-	-	-

8.3 6" Encapsulated-resin filled motor 50 HZ

Three Phase(One Cable Only)

220-240V50HZ			Metric Cable Size · Square Millimeters · Maximum Length in Meters																
MOTOR	HP	KW	1.5	2.5	4	6	10	16	25	35	50	70	95	120	150	185	240	300	400
6CF7205D	5.5	4.0	29	49	79	118	197	316	484	662	909	1225	1571	1887	2213	2559	3033	3478	4022
6CF7215D	7.5	5.5	-	29	59	88	147	236	374	512	700	947	1223	1469	1726	2012	2397	2752	3206
6CF7225D	10	7.5	-	-	39	59	108	167	266	364	493	670	857	1035	1212	1400	1666	1903	2199
6CF7245D	15	11.0	-	-	-	38	76	115	182	258	354	479	623	757	891	1035	1236	1428	1668
6CF7265D	20	15.0	-	-	-	-	57	86	144	192	269	365	481	587	693	808	972	1126	1319
6CF7275D	25	18.5	-	-	-	-	-	68	108	157	216	294	383	471	560	648	786	904	1071
6CF7285D	30	22.0	-	-	-	-	-	58	97	126	184	252	321	389	467	544	651	758	885

380-415V50HZ			Metric Cable Size · Square Millimeters · Maximum Length in Meters																
MOTOR	HP	KW	1.5	2.5	4	6	10	16	25	35	50	70	95	120	150	185	240	300	400
6CF7405D	5.5	4.0	89	149	248	368	606	965	1472	2009	2755	3681	4725	5680	6645	7700	9133	-	-
6CF7415D	7.5	5.5	69	109	188	277	466	734	1131	1547	2123	2847	3671	4425	5199	6042	7193	8264	9624
6CF7425D	10	7.5	49	79	128	197	326	523	800	1096	1491	2005	2578	3092	3626	4199	4979	5700	6600
6CF7445D	15	11.0	-	59	88	137	236	373	580	797	1102	1486	1919	2312	2726	3178	3798	4379	5117
6CF7465D	20	15.0	-	-	68	107	176	284	440	607	842	1136	1469	1782	2105	2468	2958	3418	4025
6CF7475D	25	18.5	-	-	-	78	137	226	344	482	669	896	1172	1418	1674	1960	2354	2729	3211
6CF7485D	30	22.0	-	-	-	-	117	185	292	400	556	751	975	1180	1404	1639	1960	2273	2673
6CF8505D	40	30.0	-	-	-	-	-	138	216	305	414	562	729	887	1045	1212	1449	1676	1962
6CF8515D	50	37.0	-	-	-	-	-	107	175	234	331	449	575	693	820	956	1142	1317	1542

Three Phase(Y-△ Two Cable)

220-240V50HZ			Metric Cable Size · Square Millimeters · Maximum Length in Meters																
MOTOR	HP	KW	1.5	2.5	4	6	10	16	25	35	50	70	95	120	150	185	240	300	400
6CF7205W	5.5	4.0	39	69	128	188	327	535	812	1110	1526	2061	2656	3191	3746	4351	5173	5947	6898
6CF7215W	7.5	5.5	29	39	88	128	217	355	562	769	1045	1420	1834	2199	2584	3018	3590	4123	4804
6CF7225W	10	7.5	9	29	59	88	157	246	394	542	739	1005	1282	1548	1814	2100	2494	2850	3293
6CF7245W	15	11.0	-	28	38	57	115	173	270	386	531	724	936	1139	1342	1564	1863	2153	2520
6CF7265W	20	15.0	-	-	28	38	86	125	211	289	404	549	722	876	1040	1214	1455	1686	1975
6CF7275W	25	18.5	-	-	-	29	58	98	157	235	324	442	570	707	835	973	1179	1356	1602
6CF7285W	30	22.0	-	-	-	-	58	87	145	184	272	379	476	583	700	817	973	1138	1323

380-415V50HZ			Metric Cable Size · Square Millimeters · Maximum Length in Meters																
MOTOR	HP	KW	1.5	2.5	4	6	10	16	25	35	50	70	95	120	150	185	240	300	400
6CF7405W	5.5	4.0	149	248	397	606	1013	1610	2454	3369	4601	6171	7960	9571	-	-	-	-	-
6CF7415W	7.5	5.5	99	159	277	416	694	1101	1696	2321	3184	4266	5506	6637	7798	9058	-	-	-
6CF7425W	10	7.5	69	119	188	297	485	782	1199	1645	2239	3012	3874	4647	5450	6312	7492	8572	-
6CF7445W	15	11.0	39	89	128	208	357	565	873	1200	1666	2286	2896	3492	4117	4801	5744	6617	7738
6CF7465W	20	15.0	29	59	98	158	266	424	662	919	1274	1719	2223	2698	3182	3735	4477	5168	6087
6CF7475W	25	18.5	-	39	68	118	206	334	512	719	1004	1339	1753	2128	2512	2935	3527	4088	4817
6CF7485W	30	22.0	-	-	68	98	176	274	441	598	834	1128	1472	1776	2120	2473	2954	3426	4034
6CF8505W	40	30.0	-	-	-	69	128	207	325	453	621	838	1094	1331	1567	1814	2169	2514	2938
6CF8515W	50	37.0	-	-	-	-	97	156	263	351	497	673	859	1034	1230	1435	1708	1972	2313

8.4 6" Encapsulated-resin filled motor 60 HZ

Three Phase(One Cable Only)

220-230V60HZ			AWG COPPER WIRE SIZE(Maximum Length in Feet)												MCM COPPER WIRE SIZE(Maximum Length in Feet)						
MOTOR	HP	KW	14	12	10	8	6	4	3	2	1	0	00	000	0000	250	300	350	400	500	
6CF7106D	5	3.7	130	220	360	570	900	1400	1750	2150	2640	3230	3960	4760	5760	6530	7420	8310	9060	-	-
6CF7116D	7.5	5.5	-	150	250	410	640	1000	1250	1540	1890	2310	2830	3390	4100	4650	5270	5890	6410	7410	-
6CF7126D	10	7.5	-	-	180	300	480	750	940	1160	1430	1740	2140	2590	3140	3560	4070	4570	4980	5800	-
6CF7136D	15	11.0	-	-	-	200	320	500	630	770	950	1160	1430	1730	2090	2370	2706	3020	3300	3830	-
6CF7146D	20	15.0	-	-	-	-	230	370	460	560	700	860	1060	1280	1560	1780	2030	2280	2490	2900	-
6CF7156D	25	18.5	-	-	-	-	-	300	370	470	570	700	860	1050	1280	1450	1660	1870	2040	2380	-
6CF7166D	30	22.0	-	-	-	-	-	240	300	380	470	570	700	860	1050	1190	1370	1530	1670	1960	-

380V60HZ			AWG COPPER WIRE SIZE(Maximum Length in Feet)												MCM COPPER WIRE SIZE(Maximum Length in Feet)						
MOTOR	HP	KW	14	12	10	8	6	4	3	2	1	0	00	000	0000	250	300	350	400	500	
6CF7206D	5	3.7	390	630	990	1570	2460	3830	4730	5810	7150	8740	-	-	-	-	-	-	-	-	-
6CF7216D	7.5	5.5	260	430	680	1070	1680	2600	3210	3940	4850	5920	7180	8650	-	-	-	-	-	-	-
6CF7226D	10	7.5	190	310	500	780	1230	1890	2340	2860	3510	4260	5140	6160	7270	8140	9190	-	-	-	-
6CF7236D	15	11.0	-	-	360	570	900	1390	1730	2120	2630	3210	3910	4730	5640	6380	7270	8070	8790	-	-
6CF7246D	20	15.0	-	-	-	430	680	1060	1320	1630	2010	2470	3020	3680	4400	5000	5720	6370	6970	8020	-
6CF7256D	25	18.5	-	-	-	350	560	860	1080	1320	1640	2010	2470	2990	3580	4060	4640	5170	5650	6490	-
6CF7266D	30	22.0	-	-	-	-	450	710	880	1080	1340	1650	2020	2450	2930	3330	3810	4240	4630	5340	-
6CF8276D	40	30.0	-	-	-	-	-	520	650	810	1000	1230	1510	1830	2180	2480	2830	3150	3450	3960	-
6CF8286D	50	37.0	-	-	-	-	-	-	520	630	790	960	1170	1420	1700	1940	2210	2460	2680	3080	-

460V60HZ			AWG COPPER WIRE SIZE(Maximum Length in Feet)												MCM COPPER WIRE SIZE(Maximum Length in Feet)						
MOTOR	HP	KW	14	12	10	8	6	4	3	2	1	0	00	000	0000	250	300	350	400	500	
6CF7306D	5	3.7	580	930	1480	2330	3650	5680	-	-	-	-	-	-	-	-	-	-	-	-	-
6CF7316D	7.5	5.5	400	660	1040	1640	2570	3990	4970	6100	7480	-	-	-	-	-	-	-	-	-	-
6CF7326D	10	7.5	300	490	780	1230	1930	3010	3750	4620	5670	6960	-	-	-	-	-	-	-	-	-
6CF7336D	15	11.0	-	330	530	840	1320	2070	2570	3170	3890	4760	5850	7050	-	-	-	-	-	-	-
6CF7346D	20	15.0	-	-	390	620	980	1530	1910	2360	2900	3560	4370	5280	-	-	-	-	-	-	-
6CF7356D	25	18.5	-	-	-	510	800	1260	1570	1930	2380	2930	3600	4350	5280	-	-	-	-	-	-
6CF7366D	30	22.0	-	-	-	420	660	1040	1290	1600	1980	2430	2980	3610	4390	5010	5720	-	-	-	-
6CF8376D	40	30.0	-	-	-	-	490	780	970	1200	1480	1820	2230	2690	3270	3710	4220	-	-	-	-
6CF8386D	50	37.0	-	-	-	-	-	630	790	970	1190	1460	1790	2170	2620	2980	3380	3790	4140	4800	-

Three Phase(Y-△ Two Cable)

220-230V60HZ			AWG COPPER WIRE SIZE(Maximum Length in Feet)												MCM COPPER WIRE SIZE(Maximum Length in Feet)						
MOTOR	HP	KW	14	12	10	8	6	4	3	2	1	0	00	000	0000	250	300	350	400	500	
6CF7106W	5	3.7	200	330	540	870	1370	2120	2660	3260	4000	4900	6000	7220	8740	9910	-	-	-	-	-
6CF7116W	7.5	5.5	140	230	380	610	950	1500	1860	2300	2830	3450	4220	5070	6130	6940	7870	8800	9580	-	-
6CF7126W	10	7.5	100	170	270	450	720	1130	1410	1730	2140	2620	3220	3880	4710	5340	6110	6850	7480	8700	-
6CF7136W	15	11.0	-	-	180	300	470	750	940	1160	1430	1750	2140	2590	3130	3560	4050	4530	4960	5750	-
6CF7146W	20	15.0	-	-	130	210	340	550	690	840	1060	1290	1590	1920	2340	2660	3040	3420	3740	4360	-
6CF7156W	25	18.5	-	-	-	170	280	450	560	700	860	1050	1300	1580	1920	2180	2490	2800	3060	3570	-
6CF7166W	30	22.0	-	-	-	130	220	360	450	560	700	860	1060	1290	1570	1790	2050	2300	2510	2940	-

380V60HZ			AWG COPPER WIRE SIZE(Maximum Length in Feet)												MCM COPPER WIRE SIZE(Maximum Length in Feet)						
MOTOR	HP	KW	14	12	10	8	6	4	3	2	1	0	00	000	0000	250	300	350	400	500	
6CF7206W	5	3.7	590	940	1480	2340	3670	5710	7060	8660	-	-	-	-	-	-	-	-	-	-	-
6CF7216W	7.5	5.5	390	650	1010	1600	2520	3900	4820	5910	7280	8880	-	-	-	-	-	-	-	-	-
6CF7226W	10	7.5	290	460	740	1170	1830	2820	3490	4260	5230	6350	7670	9190	-	-	-	-	-	-	-
6CF7236W	15	11.0	200	330	530	860	1350	2090	2590	3180	3940	4820	5870	7100	8460	6110	6850	-	-	-	-
6CF7246W	20	15.0	150	250	400	640	1030	1600	1980	2450	3030	3720	4540	5530	6620	7520	4180	9580	-	-	-
6CF7256W	25	18.5	-	200	320	530	830	1300	1620	1980	2460	3020	3700	4490	5370	6090	6970	7750	8480	9730	-
6CF7266W	30	22.0	-	-	260	410	680	1060	1320	1630	2010	2480	3030	3670	4400	4990	5710	6360	6950	8000	-
6CF8276W	40	30.0	-	-	-	310	500	780	980	1200	1500	1850	2260	2740	3280	3730	4240	4720	5170	5940	-
6CF8286W	50	37.0	-	-	-	240	390	610	790	960	1200	1460	1780	2160	2580	2930	3340	3720	4070	4660	-

9 Assembly of motor and pump

The instructions below refer to the motor use only. Please consult the pump manufacturer for the assembly instruction.

- Place the motor and the pump horizontally and level.
- Turn the motor shaft by hand to make sure it can turn smoothly after overcoming the adhesive friction.
- Apply waterproof, acid-free grease to lubricate the internal teeth of coupling.
- Align the cable guard of the pump with the lead exit of the motor, and to guide pump and motor together.
- If deemed necessary, place spring rings on the studs and tighten the nuts . Strictly observe the tightening torques of the unit manufacturers.
- There must be no rigid connection in the radial and axial clearance of the motor shaft since otherwise the motor and pump will be damaged during synchrony.
- Protect coupling spot against contact.

9.1 Fusing and the motor protection.

- In order to be able to turn the system off any time, an external mains switch is recommended.
- Allow for an emergency stop
- Apply fuses for each individual phase to protect the motor
- Apply overload protector in the switch box of the motor
 - ✓ Warranty is void without thermal protection
 - ✓ Trip time at 500% I_n < 10 sec.
 - ✓ Overload setting at operation current.

9.2 Earthing

- Consider motor power rating when dimensioning the earth connection in accordance with IEC 364-5-54 EN60034-1
- Motor has to be earthed
- Provide good contact of the protective conductor terminal.

9.3 Connection examples

- 3-phase connection. The connection features the usual circuit with a clockwise rotating field and a counterclockwise rotation for the motor shaft, make sure its direction of rotation corresponds to that the pump.

9.3-1 4" Single Phase - 2 wire

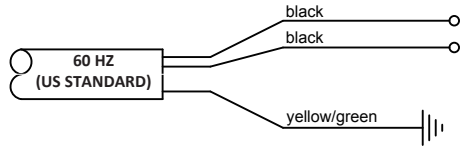
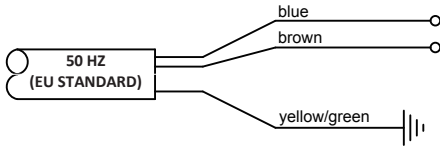

9.3-2 4" Single Phase - 3 wire

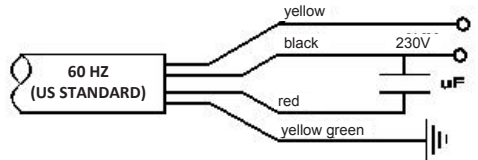
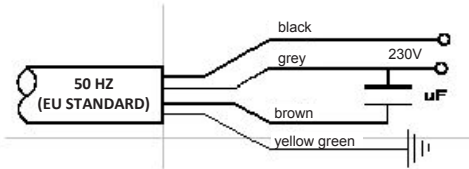

9.3-3 4" Three Phase & 6" Three Phase (DOL)

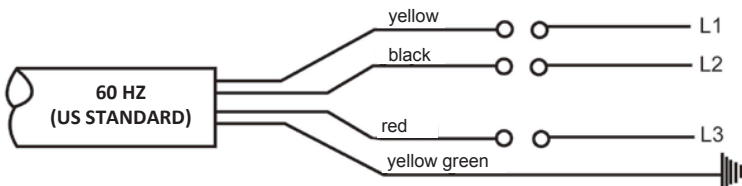
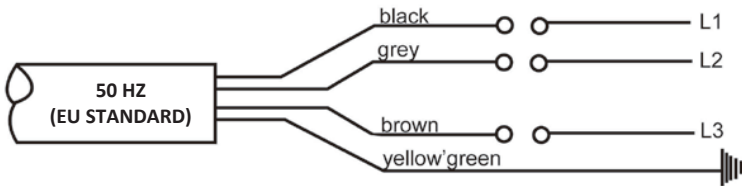

9.3-4 6" Three Phase (Y-△ Two Cable)

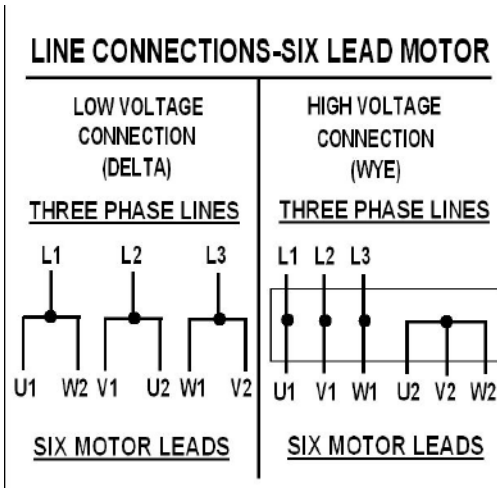

10 Electrical connection

The connection examples below refer to the motor use only. The customer is recommended to check the specifications on the nameplate and the data sheet before installation.

10.1 Checking/ replenishing the motor filling

Submersible canned (Encapsulated) type motors are a water lubricated design. The motors are factory prefilled with a mixture of water and non-toxic antifreeze. No re-filling before the installation is required. Loss of a certain amount of liquid will not damage the motor since the filter check valve will allow lost liquid to be refilled by filtered well water while installation.

If there is a reasonable sign to find that there has been a considerable amount of leakage, please consult the factory for checking procedures of the motor. Do not attempt to disassemble the motor by yourself since it can only be opened and adjusted with special tools.

10.2 Measuring the insulation resistance

Measure the insulation resistance before and while the process that assembled pump and motor being placed to the application spot.

The motor is well functioned if the insulation resistance in a 20 °C environment is at least:

Minimum insulation resistance with the connection of an extension cable:

- For a new motor > 4 MΩ
- For a used motor > 1 MΩ

Minimum insulation resistance without the connection of an extension cable:

- For a new motor > 400 MΩ
- For a used motor > 20 MΩ

11 Work on the motor

- Regarding the troubleshooting and rectification on the entire system please strictly follow the appropriate instruction of the motor and pump manufacturer.
- Do not apply any modifications or conversions to the motor or its electrical connections without permission of the supplier.
- Never attempt to disassemble the motor by yourself since it can only be opened and adjusted with special tools.
- De-energize system to the beginning of the work and protect it against unintended re-energizing
- After completion of the work apply all safety and protective devices completely and check for their function.

12 Water Temperature and Flow

Submersible Canned (Encapsulated) type motors are designed to operate up to maximum service factor horsepower in water up to 30 °C. A flow of 0.25 ft/s for 4" motors rated (3 hp) 2.2 KW and higher, and 0.5 ft/s for 6" is required for proper cooling. The table below shows minimum flow rates, in gpm, for various well diameters and motor sizes.

Minimum GPM required for motor cooling in water up to 30 °C		
Casing or sleeve ID inches(mm)	4"motor (3-10HP) 0.25FT/S GPM(L/M)	6"Motor 0.50 FT/S GPM (L/M)
4 (102)	1.2 (4.5)	-
5 (127)	7 (26.5)	-
6 (152)	13 (49)	9 (34)
7 (178)	20 (76)	25 (95)
8 (203)	30 (114)	45 (170)
10 (254)	50 (189)	90 (340)
12 (305)	80 (303)	140 (530)
14 (356)	110 (416)	200 (760)
16 (406)	150 (568)	280 (1060)

0.25 ft/s=7.62cm/sec 0.50 ft/s=15.24cm/sec 1 inch=2.54cm

If the pump installation does not provide the minimum flow shown in the table above, the customer must use a flow inducer sleeve (flow sleeve).

A flow sleeve are requested when:

- The diameter of the water well is too large to reach the flow requirements.
- Pump is in an open water
- Pump is in a rock well or below the well casing.
- The well is "top-feeding" (aka cascading).
- The pump is set in or below filters

13 Installation Position

Motors can be installed either horizontally or vertically. In either position, the motor must be sleeved and fully submerged at least one foot to prevent vortex (air entering intake).

When a motor is installed in a horizontal position, the shaft must not fall below the horizontal plain. We recommend that a Flow Sleeve be installed on all motors mounted in a horizontal position. Make sure that the motor is fully supported when mounted in the horizontal position.

Note: Do not let pump sit on bottom of tank. Place on an elevated surface for cooling, to avoid injecting debris and absorb vibration.

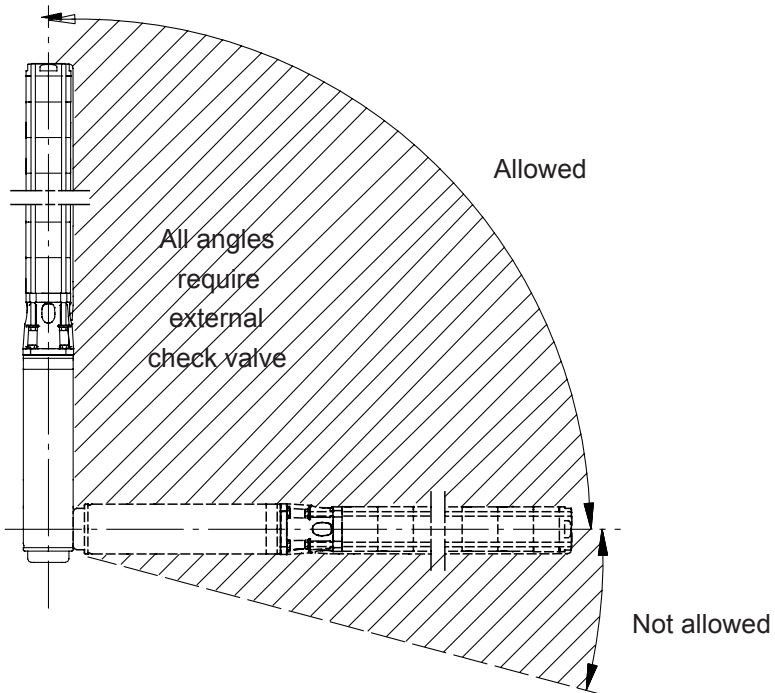



GOL PUMPS TECHNOLOGY INC

3750 NW 114 AVE #6 MIAMI , FL 33178

Ph: +1 (786) 615 8984

Fax: +1 (786) 615 7043

www.golpumps.com

Info@golpumps.com