

EA Series

End Suction Centrifugal Pump

User Manual

Content

1. Brief Description
2. Assembly and Disassembly
3. Installation
4. Starting, Checking, Stopping, Running and Maintenance
5. Troubleshooting
6. Installation Dimensions
7. EA Direct-coupled with Motor Installation Dimensions

1. Brief Description

EA pump complies fully to the European Standard BS EN733 / DIN24255 of performance and dimensions. They are used for pumping clean water or liquids similar to water, achieving wide application in plants, mines, city water supplies, air-conditioning coolers, firefighting system and irrigation.

Pumps of the same model have different performance levels basing on different diameter after impeller trimming. Overall the whole series, there are only four sizes of shaft and five of bearing housing. As long as their bearing housings are of the same size, different pumps can interchange chief parts such as shaft, shaft sleeve, shaft seal, impeller nut, etc.

EA pump is also very easy to be installed and maintained. Back pull-out design, driven through flexible coupling, so that pump casing and motor can remain in position while other spare parts are removed.

Design	Performance and dimensions referring to BS EN733/ DIN24255
Structure	Horizontal, Axial End-Suction, Single-Stage, Single-Suction, Volute Casing, Back pull-out, Centrifugal Pump
Flange	DIN2501 (ISO7005.2 / GB/T17241.6 PN1.6) standard, ANSI B16.5 Class150lb optional
Rotation	Clockwise viewing from the drive side

Material

Casing	Cast Iron standard, Ductile Iron, Stainless Steel optional
Impeller	Bronze standard, Cast Iron, Stainless Steel optional
Shaft	ASTM420 standard, ASTM304, ASTM316, ASTM1045 optional
Shaft Seal	Mechanical Seal standard (Carbon-Ceramic/Viton standard, Caron-Sic/Viton optional) , Gland Packing optional

Operating Range

Flow Rate (Q)	2-1100m ³ /h
Head (H)	2-150m
Speed	1450 or 2900 rpm (50Hz) 1750 or 3500 rpm (60Hz)
Temperature	-10°C to 105°C
Working Pressure	10 Bar standard, 16 Bar on request

Model Form For example.

Structure Drawing

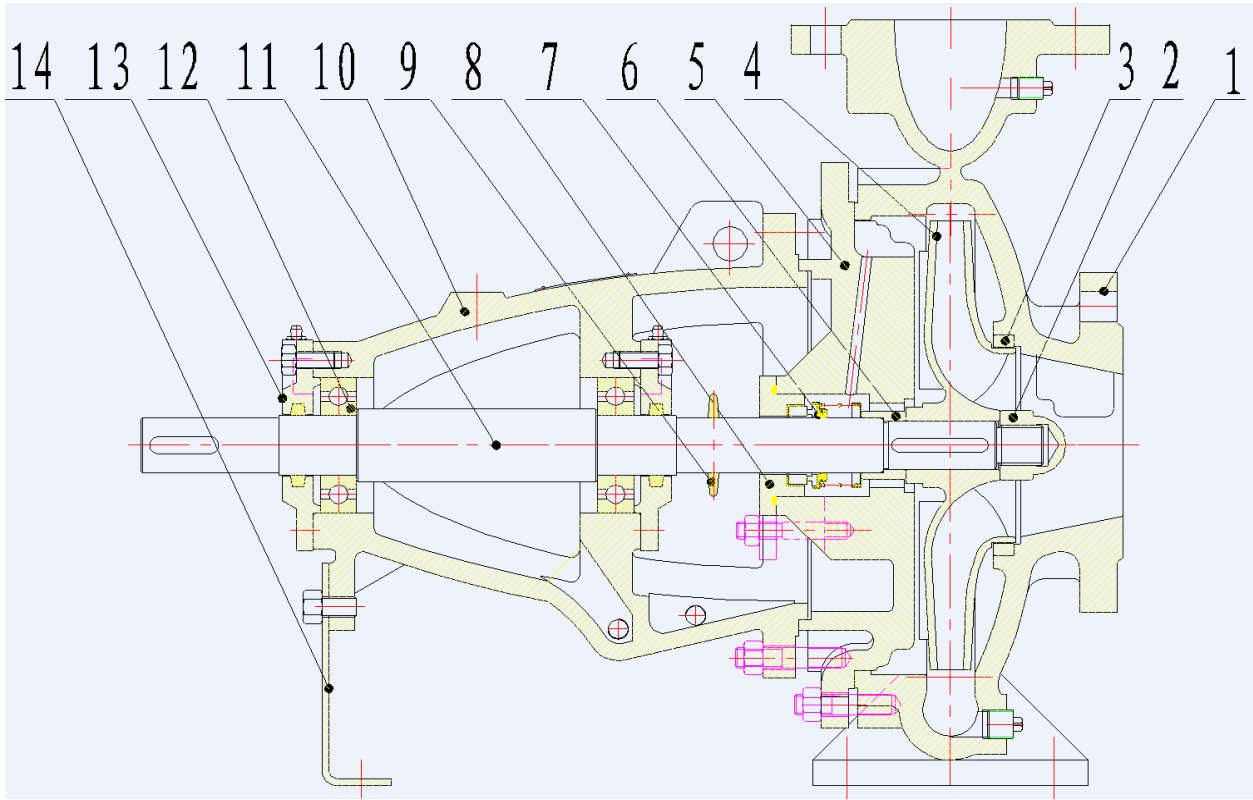

Main Parts

Gland Packing

No.	Part Name
1	Volute Casing
2	Impeller Nut
3	Wear Ring
4	Impeller
5	Casing Cover
6	Shaft Spacer
7	Mechanical Seal
8	Seal Cover
9	Slinger 挡水圈
10	Bearing Housing
11	Shaft
12	Bearing
13	Bearing Cover
14	Support Foot
15	Packing Sleeve
16	Seal Cage
17	Gland Packing
18	Gland Cover

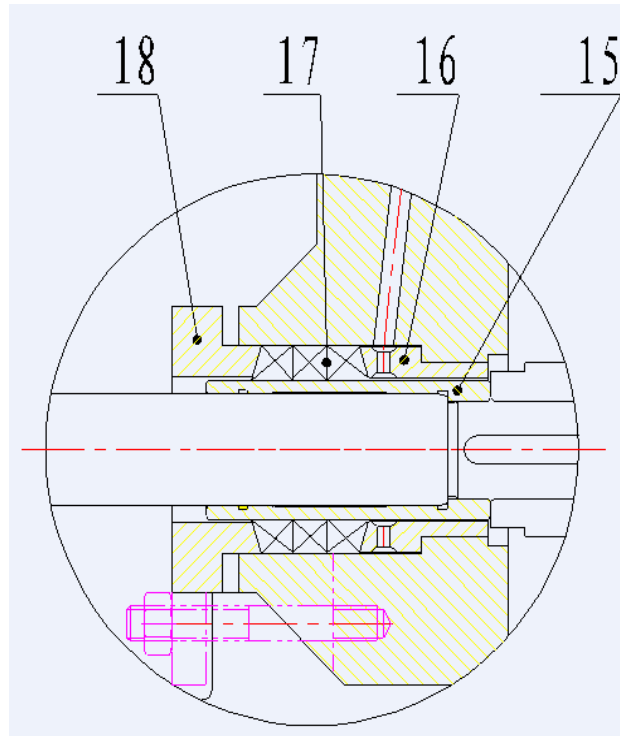

2. Assembly and Disassembly

Ensure no parts are missing or defective before assembly, wipe every part clean then start.

- 1). Tighten the bolts, screws and other fasteners to each relevant assembly parts.
- 2). Lay O rings, gaskets, felted wool or other sub-seals in each relevant assembly parts.
- 3). Place wearing ring and gaskets into casing cover.
- 4). Mount ball bearings to shaft, and joint shaft and bearing housing together, close bearing cover with bolts then put slinger onto shaft.
- 5). Depress stationary seal ring into mechanical seal cover, put seal cover、mechanical seal、shaft sleeve one by one onto shaft.
- 6). Fasten casing cover onto bearing housing by fastening bolts, place key into shaft, set impeller on key, put lock washer and impeller nut onto shaft against impeller and tighten them.
- 7). Fix all the assembly parts where mentioned above into volute casing, tighten all the bolts and screws for volute casing, casing cover and mechanical seal.

3. Installation

Correct way of pump installation makes great sense of stable performance and long service life. All the procedure of mounting and adjusting should be carried out carefully. For outline and dimension, see the outline picture and dimension table.

Mounting and adjusting

- 1). Remove all the dust and dirt on base plate then place it onto ground foundation.
- 2). Check foundation level by level meter, iron wedge or steel shims can be used for adjustment.
- 3). Pour concrete into baseplate and foundation bolts holes.
- 4). Check foundation bolts to see if it is loose or not after concretion, and then tighten the bolts, check level again.
- 5). Clean the mounting surfaces of baseplate、pump foot and motor foot, and fix pump and motor onto baseplate.
- 6). Make sure the clearance between couplings is left from 2-4mm. The centerline of pump should be in alignment with that of motor, axial and radial tolerance is 0.2mm. Shims are available for alignment.

4. Starting, Checking, Stopping, Running and Maintenance

4.1. Starting

- 1). Check that the direction of the motor **rotation** corresponds to the direction arrow on the pump casing before joint pump and motor together. Ensure that the pump is running freely without seizure or friction.
- 2). Turn down discharge valve.
- 3). Fill the pump with liquid or priming with a vacuum pump.
- 4). Switch on power, gradually turn up discharge valve after pump operation runs normally to achieve the target performance.

Caution: 3 minutes is the Max. continuous working time for a pump to operate with closed discharge valve.

4.2 Checking

- 1). Check direction of pump rotation, which should be clockwise viewing from the drive side.
- 2). Check **alignment of the couplings** both of pump and motor before using. **Over-tolerance** will damage flexible elements in a short time, and also cause over standard vibration as well as noise.
- 3). Check leakage of gland packing and tightness of gland cover; make them adequate to the job. If it is fitted with mechanical seal, make sure that the pump is operating with water inside; otherwise the **dynamic and stationary rings** would be worn out in dry operation
- 4). Check oil level, which should be kept in the specified range by oil gauge. If it is **grease**, make sure that the bearings are filled with grease.

4.3 Stopping

- 1). Turn down discharge valve gradually, switch off the power.
- 2). **Drain away** water left inside the pump to avoid frost crack while the temperature is below 0°C.
- 3). To keep a pump out of use for a long time, disassemble it into spare parts, store them in an appropriate place after **lubrication**.

4.4 Running and Maintenance

- 1). Readings by the meters are very important in starting and running. Care must be taken to heating, leakage, vibration and noise. Abnormal cases should be handled immediately on discovery.
- 2). Bearings are not allowed to work at the temperature 40°C higher than the temperature around, and the Max. temperature is 80°C.
- 3). In normal cases, a steady drip from the gland should be in a small amount, at about 60 drops per minutes while almost non-leakage from mechanical seal.
- 4). Lubrication should be 4# Calcium Base Grease or SAE20W Oil. Pumps working at 2900 rpm should be replenished with new oil or grease every period of 2500 working hours, 1450 rpm ones should be replenished every 5000 working hours. Ball bearings should be dismantled and replaced by the new ones every 10000 working hours, and also oil cup should be thoroughly cleaned out and filled with fresh lubrication.

5. Troubleshooting

Defects	Causes	Solutions
Pump not primed, both the hands of vacuum gauge and manometer switches violently	Not enough water filled in the pump Air leakage in the pipe or meters	Filled with water again Fix the leakage
Pump not primed and high degree vacuum indicated on the vacuum gauge	Foot valve not open or clogged Suction resistance too high or suction lift too high	Check or replace the foot valve Clean or replace the inlet pipe Reduce the suction lift
No water discharged while outlet pressure is pointed by the manometer	Wrong direction of rotation Impeller clogged	Check or shorten the pipe Check the motor rotation Remove the pipe joint and clean the impeller
Lower capacity than specified value	Pump clogged Wear ring worn out	Clean pump and pipes Replace the wear ring
Too much power consumed by pump	Packing too tight Stuffing box too hot Impeller worn out Too large flow that the pump is working in.	Loosen gland packing Replace impeller Turn down discharge valve to reduce flow
Abnormal noise inside the pump Pump not primed	Flow too large Resistance too high in the inlet pipe Suction lift too high Air leakage into the inlet pipe Liquid temperature too high	Turn down discharge valve Reduce flow Fix leakage Lower liquid temperature
Bearings over-heart	Short of lubricant or lubricant too dirty Pump shaft not in alignment to that of the motor Bearing worn out	Filled with clean oil or grease Align coupling centerline Replace bearing
Vibration	Pump shaft not in alignment to that of the motor	Align coupling center line