

# TRAILER-MOUNTED SELF-PRIMING PUMPS FOR DIRTY WATERS

SERIES

**JCA**

MANUFACTURER  
**2017**

## INSTRUCTIONS

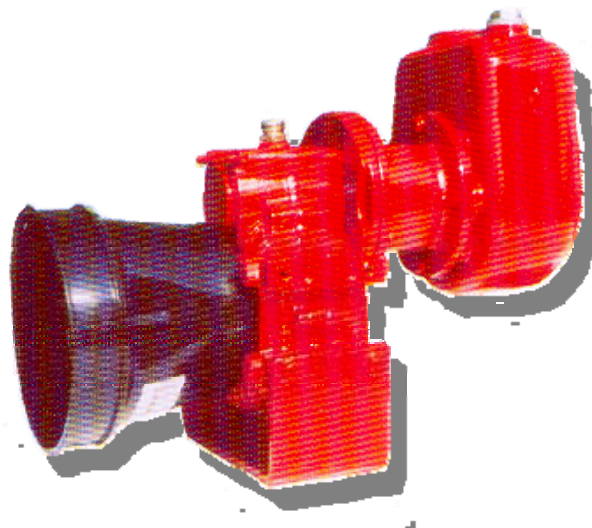

**WARNING :** BEFORE YOU OPERATE THE EQUIPMENT READ THE INSTRUCTIONS IN THIS MANUAL.  
CHECK THE PROPER MAPPING BETWEEN THE MODEL OF PURCHASED AND PUMP THE POWER OF THE TRACTOR TO WHICH YOU WISH TO APPLY THE PUMP.

## WARNINGS

**THE SAFETY AND OCCURS ONLY PUMP INSTALLED: And 'FORBIDDEN TO START THE POWER TAKE UNTIL YOU HAVE COMPLETED THE INSTALLATION OF THE PUMP (**

**WARNING: USE ONLY THE PUMP WITH CAP CARTER CORRECTLY COUPLED WITH PROTECTION EQUIPMENT TO TREE UNIVERSAL: FAILURE TO FOLLOW THIS WARNING CAN 'CAUSE SERIOUS INJURY TO ARTS.**

USED PROPERLY SHAFT SIZED ACCORDING TO THE POWER TO TRASMETTRE AND RESPONDING TO THE SAFETY SWITCH REQUIREMENTS PRESCRIBED BY THE DIRECTIVE 89/392 CE (ON THE POINT CONSULT THE SUPPLIER OF THE TREE UNIVERSAL).

CHECK BEFORE INSTALLING THE SLIDING OF HAND PUMP TURNING THE POWER TAKE: THE MOVEMENT MUST BE WITHOUT THE APPLICATION OF EXCESSIVE EFFORT.

NEVER OPERATE THE PUMP DRY (NO WATER).



**WARNING !**  
**ALL PUMPS ARE SUPPLIED WITHOUT OIL**

THE PUMP MUST BE USED WITH CLEAN WATER AND COLD. IF IT REQUIRES TO USE THE PUMP FOR TREATMENT OF SEWAGE it IS RECOMMENDED TO SEEK APPLICATION OF MECHANICAL SEAL ROTARY AND INSTALLATION OF THEIR IMPELLER: OTHERWISE TO HAPPENS A PREMATURE WEAR OF MECHANICAL TUNUTE AND BODIES.

## **1. DESCRIPTION OF THE PUMP**

### ***1.1 Auxiliary equipment***

#### **Suction Discharge flanges**

For models CA2 - CA3 do not provide the flanges, but sleeves threaded steel

#### **Carter Complete Protection**

All pumps are supplied complete with protective casing, secured with bolts to the pump in the engagement zone of the power take-off, for correct mating with the PTO shaft guard.

**IS FORBIDDEN TO OPERATE THE PUMP UNTIL YOU INSURED RING THE GUARD, THE SPECIAL CHAIN SECURITY PROTECTION SHAFT SO THAT THE FINAL DRIVE THE VEHICLE ARE FULLY PROTECTED.**

## **2. USE**

### ***2.1 INTENDED USE***

The pumps, made to be able to provide their performance on low, medium and high heads, can be used for:

- A) Transferring, filling of reservoirs and canals
- B) For fixed irrigation systems medium-range
- C) For large irrigation systems, automatic irrigators,

### ***2.2 IMPROPER USE***

**PUMPS ARE FOR USE FOR WATER PUMPING CLEAN AND COLD: USING DIFFERENT 'CONSIDERED IMPROPER AND THEREFORE EXPRESSLY PROHIBITED BY THE MANUFACTURER.**

**Dry run compromises the function of the pump causing damage to the seals.**

## **3. HANDLING**

### ***3.1 Conditions for the storage of the pump***

It is not required any special precautions for the storage of the pump, simply put the camera in a place protected from the weather. The pump is not provided with a packaging system: depositing it on the ground there are no problems of stability.

### ***3.2 Size, weight, center of gravity position***

The center of gravity of the equipment is located in the area between the centrifugal pump and multiplier.

### ***3.3 Indications for handling***

The movement is performed manually. In relation to the weight of the pump you may need the intervention of two operators.

In case it is provided an apparatus for the automatic lifting (bridge crane or the like), the equipment can be conveniently engaged between the pump and the multiplier using the bracket which joins the two groups.

## **4. INSTALLATION**

The CA series pump is connected to power through telescopic PTO shaft. The pump is usually installed on a two-wheel loaders: the carriage is then attached to the tractor.

The pump can also be fixed on a base connected to the third point of the tractor lift.

**For stability reasons, we recommend using the two-wheeled cart for the CA 2 series - CA 3 and the third base point for all others.**

### ***4.1 Pump fixing***

Fixing the pump to its foundation must be made with steel screws accompanied by flat and corresponding nuts washers.

For CA2/CA3 series pumps, use screws of section 14 mm with R 8.8 strength class.

The bolts must be tightened gradually working crosswise.

## **4.2 Installation inlet and outlet**

The suction and discharge mouths are fixed relative threaded fittings 2" (for CA2) and 3" (for CA3).

## **4.3 Suction piping**

In order to avoid the formation of air inside the suction pipe bubbles, the shortest possible length and of a diameter not less than the suction mouth, it must always be positioned with inclination towards the basin from which aspires (see figure A) .

Our Technical Department is at your disposal for the **NPSH** (Net Positive Suction Head - suction practical height).

**FIGURA A**

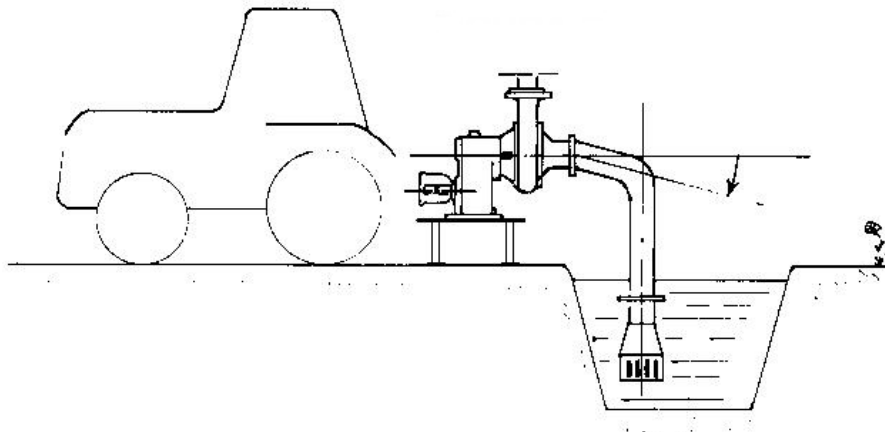

## **4.4 Filter**

The filter appropriately protected from foreign matter that might clog, must be positioned vertically, without resting on the bottom of the basin and with a swing of at least 0.5 m.

## **4.5 Delivery port**

The eventual installation of a gate valve hand wheel allows optimal adjustment of pump avoiding motor overload and cavitation.

In addition the eventual installation of a manometer in discharge facilitates the control of the plant condition.

## **5. START UP**

After installation, fill the oil in the multiplier through the fill hole. Use specific oil SAE 90.

The level will be checked by unscrewing the cap of the oil level hole. When done carefully seal the caps.



### **WARNING!**

**THE PUMP IS ALWAYS PROVIDED WITHOUT OIL. HIS STARTING WITHOUT OIL WILL CAUSE SERIOUS DAMAGE TO THE MECHANICAL PARTS.**

After 40 hours of operation (break-in period) completely replace the oil: in order to unscrew the oil filler cap and the oil drain. When emptying finished screw the oil drain plug and start filling up with oil following the procedures already described in the previous paragraph.

Additional oil changes will be carried out every 200 to 250 hours of work.

The priming of the pump must be made in such a way as to avoid the formation of air bubbles inside of the suction tubes.

### ***5.1 Connecting the pump to the PTO***

Couple the PTO pump to the coupling of the safety pin making sure the PTO shaft of the exact positioning of mail on the same: the plug must "click" positioning itself in the groove specially crafted in the pump PTO, so as to lock the come thus making it integral to the PTO itself.

**It recommends the use of cardan shaft properly sized to the power to be transmitted and has suitable caps, snap to the casing of the pump protection, exclude any possibility of the operator's limbs contact with the transmission element.**

**Caution: the maximum safety angle for a universal joint is 10 °, then it is recommended to keep the transmission angle as possible in a horizontal position by making sure that PTO of the tractor and outlet of the pump power are on the same floor". (E 'in this regard should refer to the PTO shaft manufacturer).**

## **6. PUMP USE**

For priming done :

- a) start the group by keeping the gate when this, almost entirely closed;
- b) gradually bring the steady rotation speed;
- c) open the gate until the condition desired operation.

**CAUTION: With the pump running the gland seal (if present) must drip, in order to lubricate and maintain at operating temperature. Where the loss proves excessive, you will have to act on the two recording tightening nuts, alternately, until the restoration of conditions described drip.**

**NEVER TO PREVENT TO DRIP GLAND SEAL : OPERATING WITH SEAL FULLY CLOSED IS CAUSING DAMAGE TO THE SHAFT IMPELLER.**

**If the pump is installed MECHANICAL SEAL, they should not have lost.**



### **WARNING!**

**THE PUMP MUST NEVER BE DRY, DRY RUNNING THE PUMP CAUSE SERIOUS DAMAGE TO MECHANICAL ..**

## **7. SHUTTING DOWN (STORAGE)**

At the end of the irrigation season, before proceeding to the storage of the pump:

- a) ensure that it is completely emptied of water using for the purpose the appropriate cap;
- b) lubricating the centrifugal pump making circular in place of water, a mixture of naphtha and oil: This operation preserves the mechanical parts from the risks of corrosion.



### **WARNING!**

**Note carefully the eventual elimination of oil from the multiplier so as not to forget to reset it when you return to operate the equipment**

## **8. MAINTENANCE AND REPAIR**

### **8.1 Multiplier oil change**

Will perform oil changes with the procedures and time recommended in paragraph 6.0 (Start-up).

### **8.2 Gland seal**

The replacement of the gland seal will be necessary if no longer stoppable proves the loss of liquid, even at maximum tightening the nuts (Fig. B-16).

The installation of new sealing rings (Fig. C - 15) must take place in such a way as to provide the alternation of the joints of the rings 180 ° between them.

**FIGURA B**

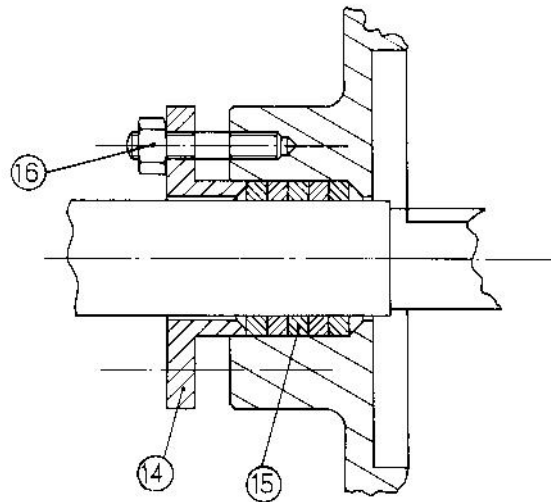

### **8.3 Impeller replacement**

With time it may be necessary to replace the impeller, subsequently to the mechanical attrition of the organ.

In order, **to equipment not connected to the PTO :**

- a) remove the suction cover
- b) unscrew the self-locking nut
- c) Remove the impeller
- d) inserting the new impeller
- e) screw the new self-locking nut
- f) reset the lid seals
- g) close the suction cover



**REPAIR SHOULD BE MADE USING ONLY GENUINE PARTS IF NOT THE MANUFACTURER DECLINES ALL RESPONSIBILITY 'IN RESPECT TO ANY PROBLEMS.**

## **9. MAINTENANCE EXTRAORDINARY MEASURES**

For extraordinary maintenance we mean all those transactions involving the restoration of organs subject to dimensional tolerances such as: bearings (locations and supports), gears and their distances. These operations require the use of technical personnel of the Manufacturer.

## **10. RISKS RELATED TO MAINTENANCE AND REPAIR**

Ordinary maintenance and repair operations pose no risk if made to stop equipment (disconnected from the PTO).

With little expertise performed operations may cause damage to mechanical parts such as bearings, threads, sealing surfaces, the media seats, transmission shafts, without, however, constitute a risk for the operator nor undergoing maintenance operations nor during use the apparatus after maintenance.

## **11. FAILURE: PROBLEMS AND POSSIBLE CAUSES**

In order to facilitate the installation and operation of the pump we list the most common problems that can occur during operation and their likely causes: for any questions please contact our Technical Department.

### **FAULTY OPERATION PROBLEMS AND POSSIBLE CAUSES**

#### **THE PUMP DOES NOT DELIVER WATER**

- 1) The pump and the suction pipe have not been filled well during priming and hold still air;
- 2) Foot valve blocked by mud, leaves or other debris
- 3) The pump is filled with water but the bottom valve, faulty, empties in the time that passes between the filling and set in motion;
- 4) Excessive suction lift;



### **THE PUMP DOES NOT HAVE A CAPACITY SUFFICIENT**

- 5) Air inlet from the shaft seal;
- 6) Rotation speed too low;
- 7) Wrong direction of rotation;
- 8) Foreign bodies in the impeller channels;
- 9) Seals on the pump or worn impeller;

### **PUMP ABSORB EXCESSIVE POWER**

- 10) too high rotational speed;
- 11) Shaft deformed;
- 12) Friction abnormal internal (the rotating parts rub against the firm);
- 13) The applied gaskets are not suited to the operating conditions;
- 14) Excessive tightening of the gland;

### **BEARINGS HAVE SHORT LIFE**

- 15) Lack of lubrication;
- 16) Foreign bodies in the bearings;
- 17) rusting of the bearings for introduction of water or for condensation of atmospheric humidity in the box bearings;

### **PUMP OVERHEATS AND LOCKS**

- 18) Excessive pressure caused by mechanical failure or by worn seals;
- 19) Bearings of fatigued pump.